



MINOLTA

5000

app-phot-col.com

With your new Minolta 5000 camera, you can get high-quality pictures with unparalleled ease. An impressive range of fully automatic features simplify camera operation:

- Automatic focusing for sharp pictures at a touch of a button.
- Automatic exposure for decision-free photography. You just point and shoot.
- Automatic film transport to eliminate film-handling errors. You just drop in a cartridge, and the camera does the rest.
- Automatic flash operation makes taking flash pictures easier than ever.

As your picture-taking skills develop, the 5000's manual exposure mode enables creative control of exposure. And for added creativity, versatile system accessories are also available, including Minolta AF lenses, Program Flash units, Data/Program Backs, and more.

You probably want to begin using your new camera right away. But before you start, please read through this owner's manual to learn how your Minolta 5000 operates.

NAMES OF PARTS



DATA PANEL

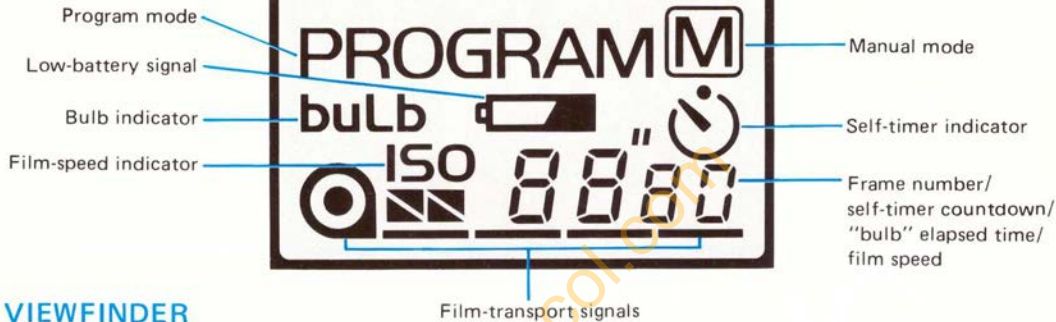

VIEWFINDER

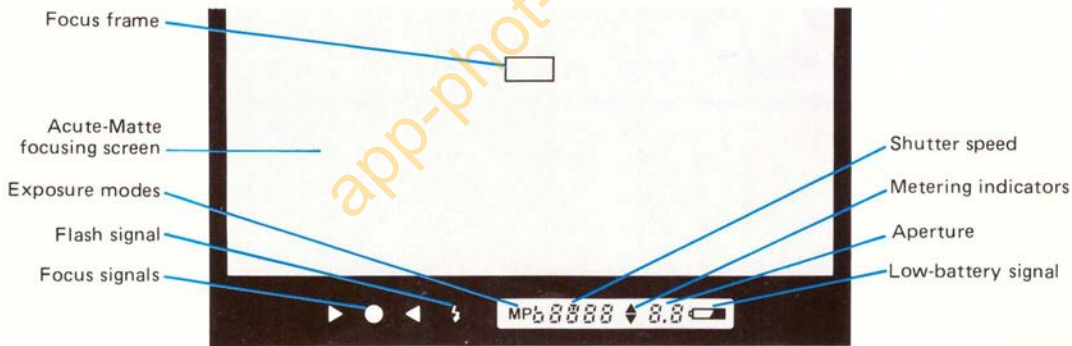

While all possible displays are shown here, only applicable displays appear during operation.

- Never touch lens or eyepiece surfaces with your fingers. Whisk away loose matter with a blower brush. To remove stubborn spots, use a sheet of photographic lens tissue. If necessary, tissue may be moistened with one drop of lens-cleaning fluid. Never place fluid directly on glass surfaces.
- It is recommended to have your camera cleaned once a year at an authorized Minolta service facility.
- When storing camera for more than two weeks, remove the batteries and keep it in a cool, dry place away from dust or chemicals, preferably in an airtight container with a drying agent such as silica gel.
- The operating range for the LCD (liquid crystal display) panels is from -20° to $+50^{\circ}\text{C}$ (15° to 120°F). At temperatures outside this range, response time and contrast will change, making displays difficult to read. At very high temperatures, display may temporarily turn black. In either case, display should return to normal after a short period of time.

- The LCD panels and the lithium battery should last approximately 10 years. The film-speed setting will blink when it is time to replace the battery. When replacement of LCD panels or battery is needed, contact an authorized Minolta service facility.

Save camera box and packing material. When shipping your camera, carefully repack it in the box, insure adequately, and use a reliable delivery service.

Before shipping your camera for repairs, contact your nearest authorized Minolta service facility.

DATA PANEL

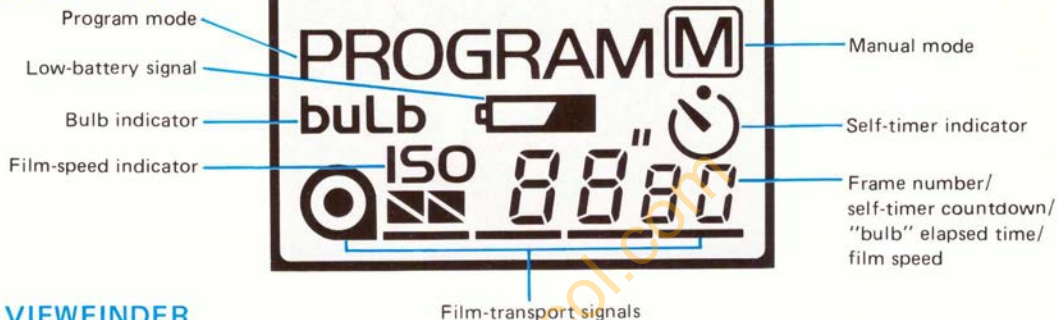

VIEWFINDER

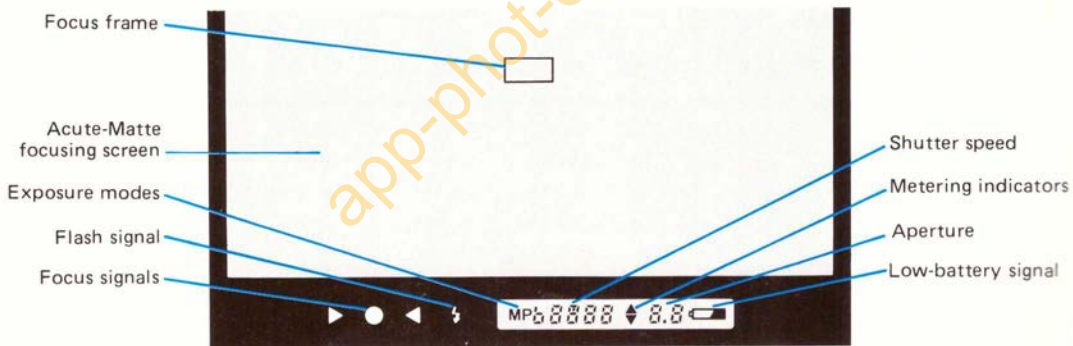

While all possible displays are shown here, only applicable displays appear during operation.

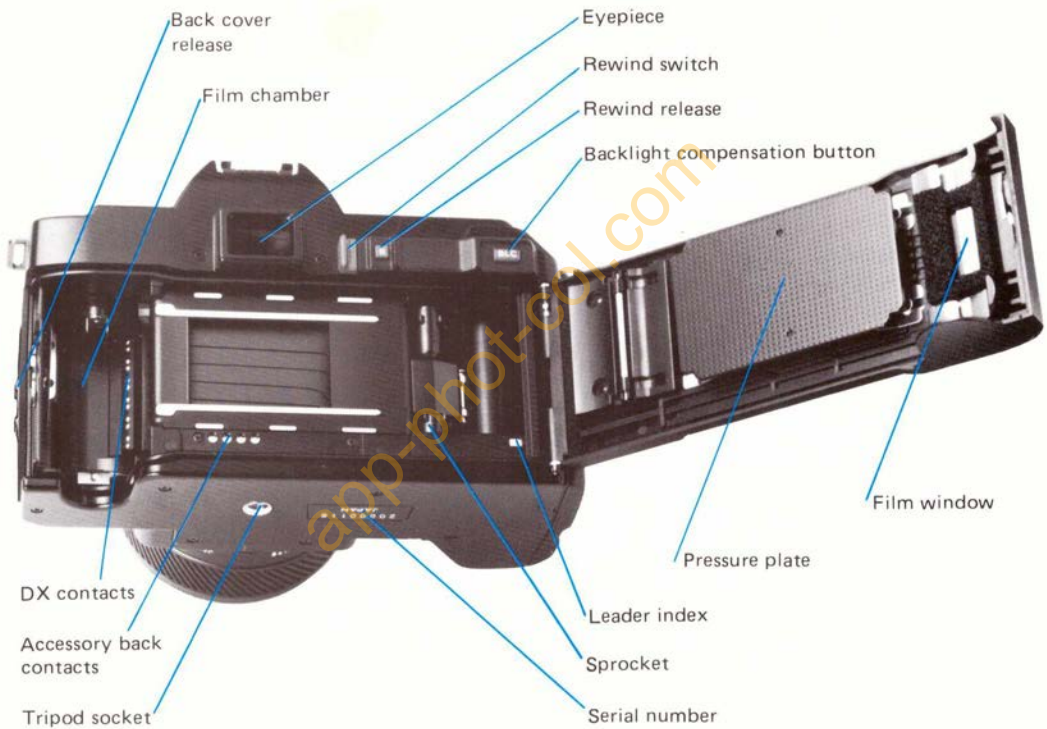

Back cover release

Eyepiece

Film chamber

Rewind switch

Rewind release

Backlight compensation button

DX contacts

Accessory back contacts

Tripod socket

Leader index

Sprocket

Serial number

Pressure plate

Film window

TABLE OF CONTENTS

BASICS

Attaching the lens	2
Batteries and power	4
Attaching the neckstrap	7
Putting camera in its case	8

OPERATING THE CAMERA 9

FILM TRANSPORT

Loading film	12
Setting the film speed manually	15
Rewinding and unloading film	16

FOCUSING

Automatic focus	18
Focus hold	20
Manual focus	21

CHOOSING THE EXPOSURE MODE 23

Program Mode for general photography	24
Backlight compensation button	26
Manual Mode for creative control	28
Aperture and shutter speed indications	30
Long exposures	34
Self-timer	36
Distance scale	38
USE OF MINOLTA AF LENSES	40
Auto multi-program selection	41
USE OF PROGRAM FLASH UNITS	42
Minolta Program Flash	43
Other accessories	44
Other flash units	48
Technical details	50
Care and storage	52

Fold out the front and back covers of this manual for easy reference to the names of parts.

ATTACHING AND REMOVING LENS

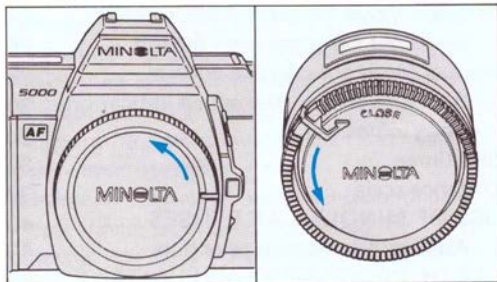

To attach:

1. Remove body cap and rear lens cap as shown.

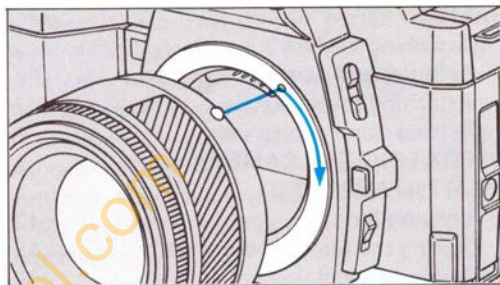

2. Align red bead on lens barrel with red dot on camera's lens mount. Insert lens bayonet into mount and turn lens clockwise until it locks in place with a click.

app-photool.co

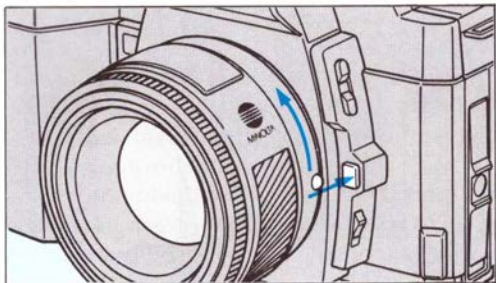

To remove:

1. While pressing lens release, turn lens counterclockwise as far as it will go, then lift lens out of mount.
2. Attach another lens or the body cap to cover the opening.

When the camera's meter is on and the lens is removed, the aperture display in the viewfinder shows "—".

NOTE

- When attaching or removing a lens, never touch anything inside the camera, especially the lens contacts or mirror.
- To protect the lens contacts and the lens elements, attach the lens caps whenever the lens is not attached to the camera.

Care of glass surfaces

- Never touch lens elements or eyepiece with your fingers. If the lens becomes dirty, clean it gently with a lens brush. Only if necessary, moisten a sheet of lens tissue with one drop of lens-cleaning fluid. Then, starting at the center and using a circular motion, lightly wipe the surface of the lens.
- Never lift the mirror or touch its surface, as this may impair its alignment. Dust specks on the mirror's surface will not affect meter readings or picture quality; if they are annoying, have the camera cleaned at an authorized Minolta service facility.

BATTERIES AND POWER

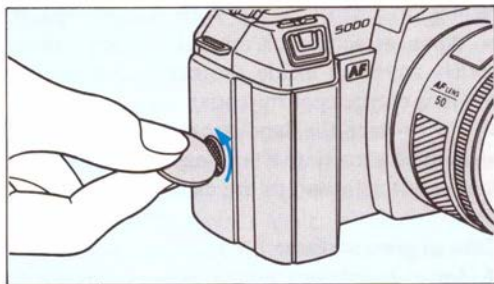

The Minolta 5000 uses four 1.5v AAA-size, alkaline-manganese batteries. These supply power for film transport, metering, autofocus-ing, and shutter release.

To load batteries:

1. Set main switch to LOCK. Using a coin or similar object, turn attaching screw until battery holder can be lifted out of handgrip.

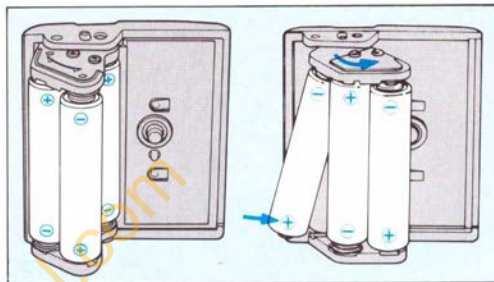

2. Load new batteries into holder with plus (+) and minus (-) ends as indicated. Holder pivots for easier loading.

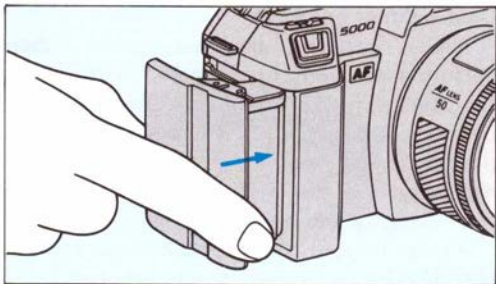

NOTE

- To remove batteries, first pull out plus (+) end of battery, then lift battery out of holder.
- Do not use nickel-cadmium or carbon-zinc batteries in the standard battery holder. Also, never mix batteries of different types, brands, or ages.
- Remove batteries if camera will not be used for more than two weeks.
- Do not dispose of used batteries in fire.
- Keep batteries away from young children.

3. Reinsert holder into handgrip. Turn attaching screw clockwise to secure holder.

After holder is attached and main switch is set to ON, exposure mode and frame number will be displayed in the data panel. If display does not appear, make sure that batteries are loaded correctly. If display still does not appear, install new batteries.

Battery Check

After taking a picture, check whether the low-battery signals in the data panel and viewfinder are blinking. If so, battery power is too low for normal operation and fresh batteries should be loaded.

Fresh batteries should also be loaded in the following cases:

- The camera is switched on, but no information is displayed in the data panel or viewfinder when the operating button is pressed.
- The shutter will not release even when the subject is in focus.
- If autofocus, film advance, or rewinding is extremely slow.

Cold-weather operation

When batteries become colder, their performance tends to decrease. Before using the camera in cold weather, always load fresh batteries. Also, carry a spare set in a warm pocket so that you can change batteries if necessary. As the batteries warm up again, their capacity will be restored.

For prolonged cold-weather use at approx. 0°C (32°F) or below, we recommend using the optional Battery Holder BH-70L or External Battery Pack EP-70 with AA-size nickel-cadmium batteries.

Memory storage

When the main switch is at LOCK position, the frame number and film-speed setting are memorized. Power for storing this data is supplied by the batteries in the battery holder. When these batteries are exhausted or the holder is removed, a built-in lithium battery supplies back-up power to store the data.

ATTACHING THE NECKSTRAP

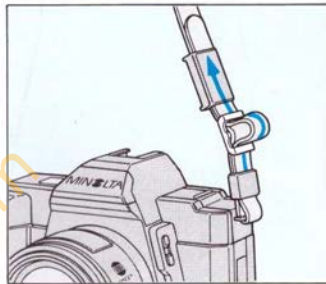
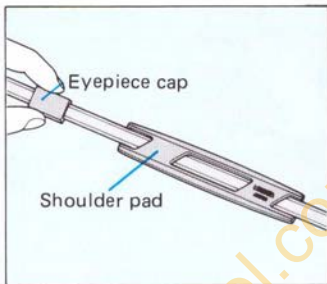
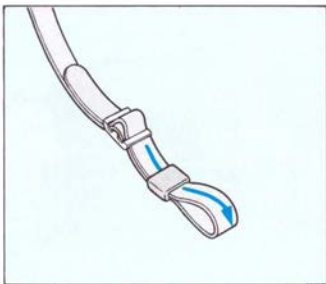

A neckstrap is supplied with your Minolta 5000. Attach it to the camera as shown.

An eyepiece cap is supplied with your camera and can be slipped onto the strap to keep it handy for use. The eyepiece cap slides over the eyepiece frame to prevent stray light

from entering the eyepiece and affecting exposure. It should be used whenever the eyepiece is not shielded by your head, as when using the self-timer or when operating the camera by remote control.

PUTTING CAMERA IN ITS CASE

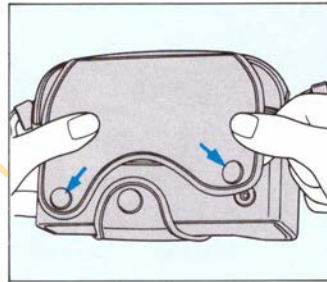
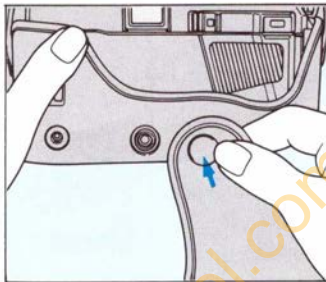
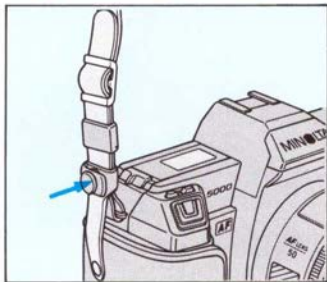

Various camera cases are available as optional accessories for the Minolta 5000.

To put camera in its case: attach front lens cap. If using a zoom lens, turn zoom ring until lens barrel is at its shortest position. Follow the diagrams to put the camera into its case.

app-phot-col.com

OPERATING THE CAMERA

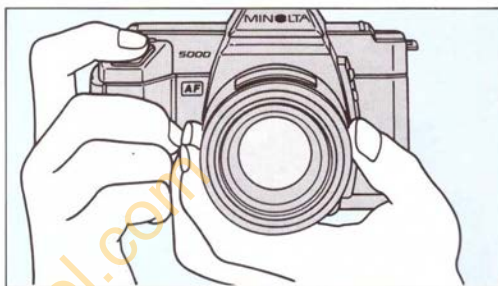
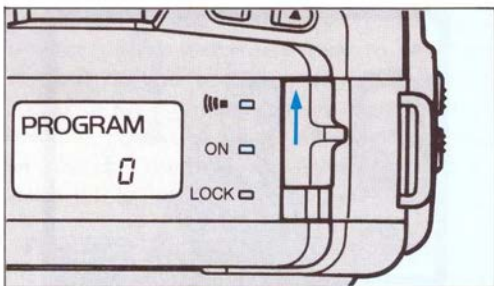

Before loading film, you should practice operating the camera. After you have learned these basic steps, you will be ready to load film and proceed to actual picture-taking.

1. Turn on the camera by moving the main switch to ON or (||) setting. At (||) setting, the camera will beep in the following cases:

- When subject is brought into focus,
- To signal a slow shutter speed when using program mode,
- At the end of the roll, or
- During self-timer operation.

When you are finished taking pictures, set main switch to LOCK to prevent battery drain or accidental exposures.

2. Grasp the camera firmly with your right hand on its handgrip and support the lens with your left hand. When using autofocus, do not touch the focusing ring.

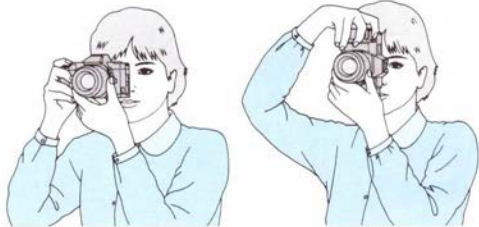

3. Look through the eyepiece and aim the camera at the subject. Hold the camera firmly against your face so that it is as still as possible. The camera can be held horizontally or vertically.



4. Touch the operating button to activate the meter. The viewfinder shows "P" for program mode or "M" for manual mode and the shutter speed and aperture settings.

- Metering continues for 10 seconds after you lift your finger from the operating button.
- If the operating button becomes dirty or oily, set the main switch to LOCK and wipe the button with a clean, dry cloth.



5. Center the focus frame on the subject and activate autofocus by pressing the operating button partway down until you feel slight resistance.

- The lens will be automatically adjusted to focus on the subject, and a green dot will glow in the viewfinder to confirm correct focus.
- Focus is locked at this position until you let up on the button.

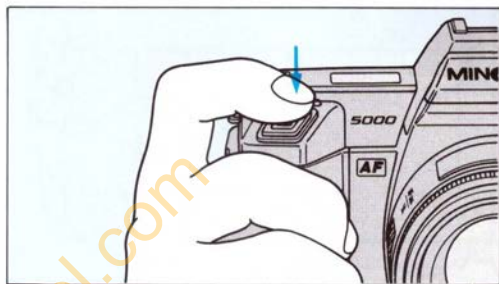

6. To take a picture, gently press the operating button all the way down. Use a smooth, steady squeeze—never a quick jab which might shake the camera and cause a blurred picture.

LOADING FILM

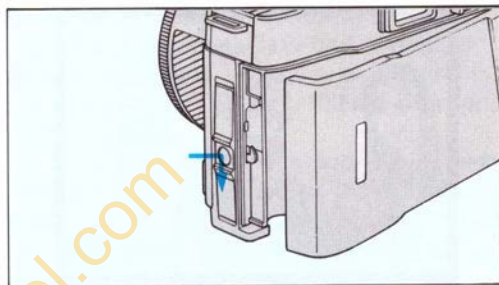
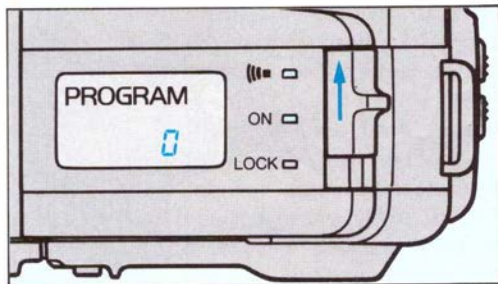

Always load film in subdued light or at least shaded from direct sunlight.

1. Set the main switch to ON or  position.
2. Check the frame counter:

- If "0" appears, it is safe to open the back cover.
- If any number other than "0" is shown, film must first be rewound (see p. 16);

3. Open the back cover by pressing the button in the center of the back cover release and sliding the release downward.

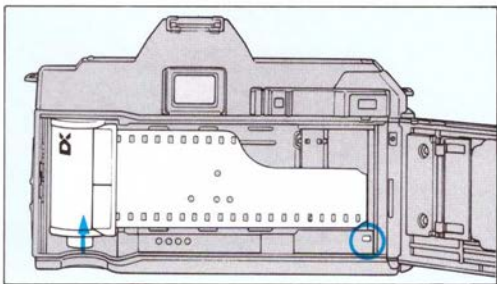

4. Place film cartridge in film chamber and extend tip of film leader past the red leader index. Make sure holes in lower edge of film engage teeth on sprocket.

- If film extends too far or does not lie flat, gently push excess back into cartridge.



5. Close the back cover by pressing until it snaps shut. The camera will automatically advance the film to the first frame, and the data panel will display the film-cartridge symbol and the frame counter will show "1". If you are using DX-coded film, the camera is now set to take pictures.

- If "1" does not appear, film is not loaded correctly. Repeat steps 3 to 5.
- When film is loaded and advancing properly, the frame number increases by one each time a picture is taken.

- Film may not advance properly if film leader is shaped incorrectly.

WRONG



RIGHT



- Do not touch any parts or areas shown in blue.

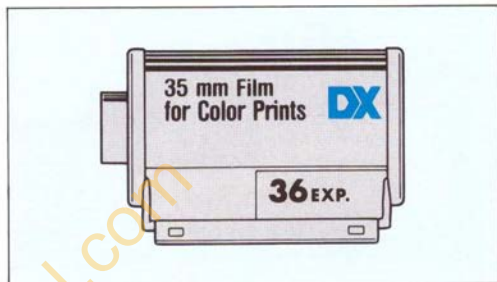
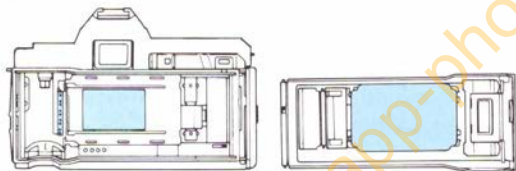

Automatic film-speed setting for DX-coded film

If you are using a DX-coded film, you do not have to set the film speed manually. To check that your film is DX-coded, look for the "DX" mark printed on the film cartridge and box. With DX-coded films, the correct ISO film speed is set automatically by the camera. The film-speed setting is displayed in the data panel while the film is being advanced to the first frame.

SETTING THE FILM SPEED MANUALLY

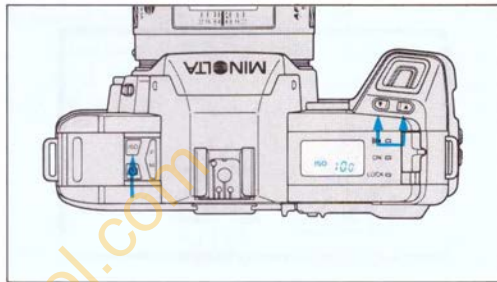
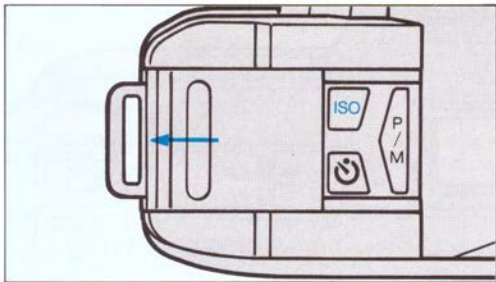

If the film you are using is not DX-coded (i.e., "DX" is not printed on the cartridge and box), you must manually set the camera for the correct ISO film speed. You can, if desired, reset the speed of a DX-coded film to a higher or lower value after the film is loaded. To set the film speed manually:

1. Slide the control-key cover on the left side of the camera to the left.
2. Hold down the key marked "ISO" and press the selector keys on the right side of the camera to set the ISO value desired.

- Press the left key to decrease the value, and the right key to increase it.
 - Each time a selector key is pressed, the value will change by 1/3 of a stop. When a selector key is held down, the value changes rapidly.
 - Any film speed from ISO 25 to ISO 6400 can be set.
3. After the desired ISO value is set, release the ISO key and close the control-key cover.
- The film-speed setting can be checked at any time by pressing the ISO key.

REWINDING AND UNLOADING FILM



After the last frame:

- Film cartridge symbol and frame number will blink,
- Camera will beep if the main switch is at (L setting, and
- Shutter locks to prevent double exposures or damage to the film.

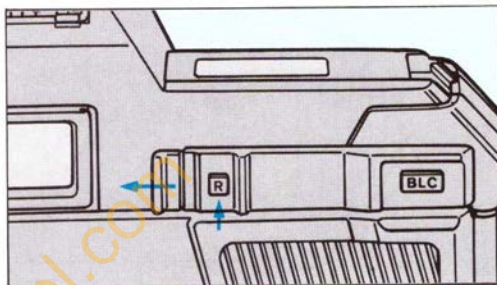

To rewind film:

1. While pressing the rewind release (marked R), slide rewind switch to left. It stays in this position; you need not hold it. During rewinding, the film-transport indicators show how far film has rewound:

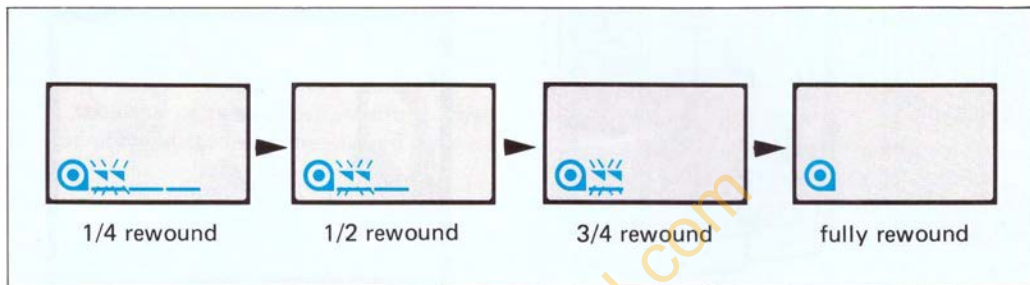

2. After you have confirmed that film is completely rewound, open the back cover and remove the film cartridge.

- If you accidentally open the camera back before the film is rewound, close the back immediately and finish rewinding the film. Light falling on the film will ruin many of the pictures; however, your quick action may save a few pictures.

- When the film is completely rewound, the rewind motor stops automatically and only the film cartridge symbol appears in the data panel. IF THE REWIND MOTOR STOPS AND THE FILM-TRANSPORT INDICATORS GO OFF, DO NOT OPEN BACK COVER; do as follows:
 - a. Slide main switch to LOCK.
 - b. Load fresh batteries.
 - c. Set main switch to ON to finish rewinding.

FOCUSING

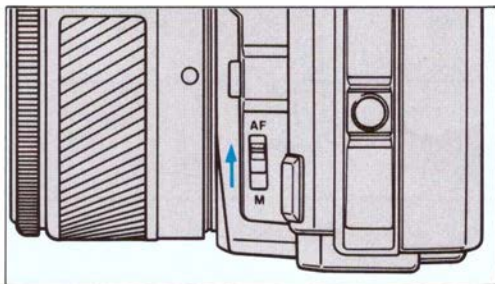

Using automatic focus

1. Set focus mode switch to AF.
2. Center focus frame on subject.
3. Press the operating button partway down and the camera will automatically focus the lens.





- When the subject is brought into focus, the green focus signal in the viewfinder glows. The camera beeps if the main switch is set at position.
- The chart on page 19 shows the focus signals that appear when using auto-focusing.

4. To take picture, press the operating button all the way down.

- To prevent out-of-focus pictures, the shutter can only be released when the green focus signal glows. If the shutter cannot be released, set the focus mode switch to M and focus the lens manually.
- If the operating button is held down, the camera will readjust the focus between frames, release the shutter, and advance the film at up to 1.5 frames per second.

Autofocus signals

	Left pointer glows: Too close to subject
	Green dot glows: Subject in focus
	Both pointers blink: Use manual focusing



Focus hold:

Center the focus frame on the subject, then press and hold the operating button halfway down. When the subject is in focus, the green focus signal glows. Focus is held as long as the operating button is pressed halfway.







Recompose the picture with the subject anywhere in frame and release shutter.

Using manual focus

1. Set the focus mode switch to M.
 2. Center the focus frame on the subject.
 3. Touch the operating button to activate focus signals.
 4. Turn the lens' focusing ring until the green focus signal glows in the viewfinder.
- The chart shows the focus signals that appear when the focus mode switch is set to M.
5. Press the operating button all the way down to take the picture.

Focus signals during manual focusing

	Turn focusing ring to the right
	Subject in focus
	Turn focusing ring to the left
	Turn focusing ring until subject appears sharpest in the viewfinder.



A



B

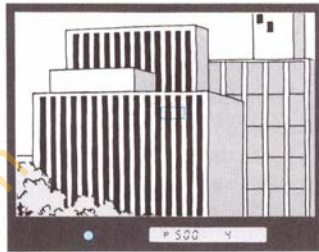

C

Focusing in special situations

The focus signals cannot be used in some situations. Follow these suggestions to obtain sharp focus:

- Subject contrast is too low (A); Focus on another subject at the same distance, then recompose photograph and release shutter.

- Subject does not fill focus frame (B) or alternating vertical stripes within focus frame (C): Focus manually on Acute-Matte screen.
- Subject is too dark: Use a Minolta Program Flash or focus the lens manually.
- Subject is extremely bright: Use a neutral-density filter.

CHOOSING THE EXPOSURE MODE

Program Mode

Program mode is designed to be the Minolta 5000's "normal" mode and is ideal for general photography. When using program mode, you just aim the camera and take the picture. The camera automatically sets the correct exposure, and no manual settings are required. When using program mode, "PROGRAM" appears in the data panel and "P" appears in the viewfinder.

When the control-key cover is closed, the camera is always set to program mode. Thus, you do not need to select this mode manually.

Manual Mode

Manual mode enables complete control of the exposure settings. When you want to control how a subject's movement, any shutter speed from 1/2000 to 4 seconds can be set. To control the overall sharpness in the picture, any available aperture can be set to obtain the effect you desire.

To select manual mode, slide the control-key cover to the left, then press the mode-selector key. "M" will appear in the data panel and viewfinder. Shutter speed and aperture can now be set by using the selector keys on the camera body.

To reset the camera to program mode, press the P/M key again or close the control-key cover.

PROGRAM MODE

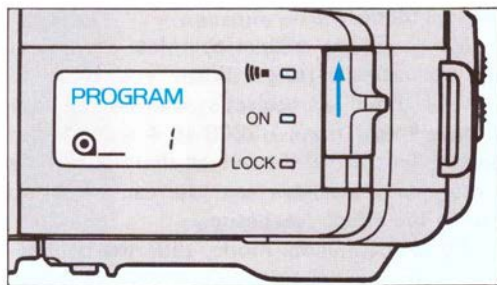

To take pictures:

1. Set the main switch to (P) position and focus mode switch to AF position. Make sure that "PROGRAM" is displayed on data panel.
2. Look through the viewfinder and center the focus frame (the small rectangle) on the subject.



3. Press the operating button partway down and hold it there.

- The camera will “beep” and the green focus signal will glow to confirm correct focus. If desired, you can recompose the picture, while holding the button partway down.
- If the camera “beeps” continuously when you touch the operating button, the shutter speed may be too slow for taking hand-held pictures. Take one of the following steps to prevent camera shake from blurring the picture:
 - a. Steady camera against a table or wall,
 - b. Mount camera on a tripod (see p. 38), or
 - c. Use a flash unit (see p. 42).
- If two pointers (between the shutter speed and aperture) blink in the viewfinder, the light level is beyond the meter’s range and exposure may not be correct.

4. To take a picture, press the operating button all the way down.

- After the exposure, the camera will automatically advance the film one frame.
- If you want to shoot several pictures in a sequence, hold down the operating button. The camera will re-adjust focus, release the shutter, and advance the film at up to 1.5 frames per second.



A. Backlit subject

Backlight compensation button

In program mode, your Minolta 5000 automatically sets the exposure based on an average of the light and dark areas seen in the viewfinder. Additional emphasis (weighting) is given to the center area where the subject is usually located. This system is called "center-weighted average metering" and produces optimum results in most cases.



B. Exposure made while pressing BLC button

However, when the subject is "backlit", i.e., the lighting behind the subject is very bright (photo A), the subject will be underexposed. To obtain a more suitable exposure, press the backlight compensation button (marked BLC) while releasing the shutter. This will increase the overall exposure, thus making the subject appear lighter (photo B).



MANUAL MODE

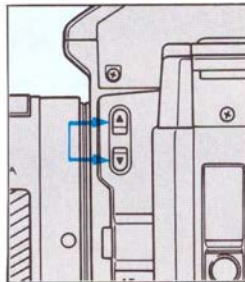
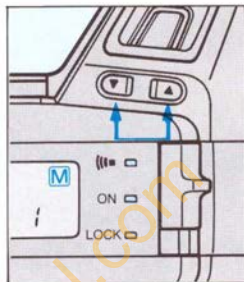
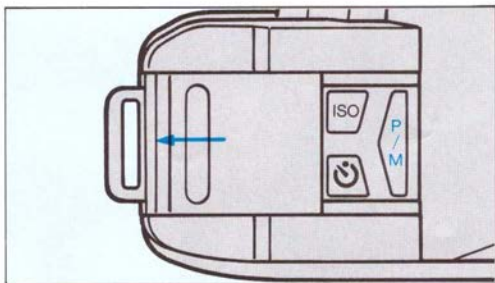

To take pictures in manual mode:

1. Set the main switch to ON or (II) position and set focus mode switch to AF position.
2. Slide the control-key cover to the left and press the mode-selector key (marked P/M). "M" will appear in the data panel and viewfinder.
3. Look through the viewfinder to compose the picture and touch the operating button to activate the meter.

4. Adjust the exposure so that both pointers appear in the viewfinder:

- Set the shutter speed by pressing the selector keys on top of the camera.
 - Set the aperture by pressing the selector keys on the left side of the camera.
 - Possible aperture and shutter speed settings are shown on p. 30.
5. After exposure is set correctly, focus and compose the picture, then release the shutter.

Metering indications:

When you touch the operating button, the shutter speed and aperture settings will appear along with the metering indicators:



Both pointers appear: Exposure is set correctly.



Upper pointer appears: Exposure is set 1/4 stop or more above normal. For normal exposure, set a faster shutter speed or a larger aperture number.



Lower pointer appears: Exposure is set 1/4 stop or more below normal. For normal exposure, set a slower shutter speed or a smaller aperture number.



Both pointers blink: Light level is beyond the meter's range, and exposure may not be correct.

APERTURE AND SHUTTER-SPEED SETTINGS

1.7

2

2.4

2.8

3.5

4

4.5

5.6

6.7

8

9.5

11

13

16

19

22

Aperture settings

At right are the aperture settings (also called f-stops) that appear in program and manual modes when using the AF 50mm f/1.7 lens. Numbers such as 6.7 and 9.5 are "half-stop" settings between the standard apertures (f-stops). For example, the half-stop setting between f/8 and f/11 is f/9.5.

Shutter-speed settings

At left are the shutter-speed settings that appear in program mode and can be set in manual mode. Numbers such as 750 and 350 appear only when using program mode. These are the "half-stop" settings between the standard shutter speeds. For example, the half-stop setting between 1/1000 sec. and 1/500 sec. is 1/750 sec.

Indications for speeds from 1/2000 sec. to 1/2 sec. are shown as: 2000 = 1/2000 sec., 1000 = 1/1000 sec., etc. Speeds of 0.7 sec. to 4 sec. are shown as: 1" = 1 sec., 2" = 2 sec., and 4" = 4 sec. "Bulb" appears only when using M mode.

Program mode	Manual mode
2000 — 1500	2000
1000 — 750	1000
500 — 350	500
250 — 180	250
125 — 100	125
60 — 45	60
30 — 20	30
15 — 10	15
8 — 6	8
4 — 3	4
2 — 0"7	2
1" — 1"5	1"
2" — 3"	2"
4"	4"
	bulb



CONTROLLING SHARPNESS



A. Aperture set at f/2

The aperture that you select determines how much of the picture will be in sharp focus: **A.** By using apertures such as f/2 or f/2.8, for example, just a small area in front of and behind the subject will be sharply focused. This is useful when you want to isolate a subject from its background, such as when taking a portrait;



B. Aperture set at f/16

B. When you want sharp focus in the entire picture, as when photographing a large group of people, f/11 or f/16 can be used.

CONTROLLING MOTION



A. Slow shutter speed

Your choice of shutter speeds affects how moving subjects will appear in the picture:

A. Slow shutter speeds, such as $1/30$ or $1/15$ of a second, will make moving subjects appear to flow;



B. Fast shutter speed

B. Fast shutter speeds, such as $1/500$ or $1/1000$ of a second, can be used to freeze the action of a moving subject. When using telephoto lenses, fast shutter speeds should be set to prevent blurred pictures caused by camera shake.

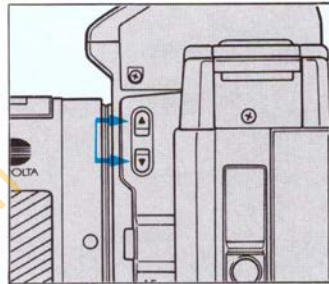
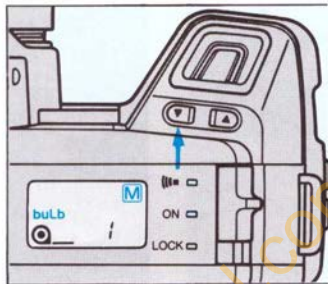
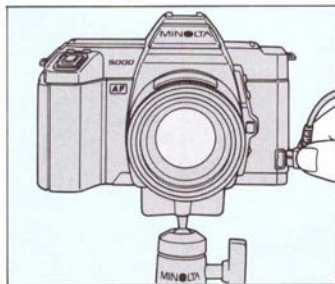

Long exposures

When you want to make exposures longer than 4 seconds, "bulb" setting can be used. The shutter will remain open as long as the camera's (or remote cord's) operating button is held down. To use "bulb" setting:

1. Mount the camera on a tripod.
2. Attach either of the optional Remote Cords RC-1000S or RC-1000L. You can then release the shutter without shaking the camera.

3. With the camera in M mode, press the left selector key on top of the camera until "bulb" appears in the data panel and viewfinder.

4. Press the selector keys on left side of camera to set the aperture desired.

5. Focus the lens. If it is too dark for auto-focusing, manually set the focus to the desired distance, using the distance scale.

6. To take the picture, press and hold down the operating button for the desired amount of time.

- Elapsed exposure time is shown in seconds in the data panel. After 99 seconds, the counter returns to "0" and counting continues.
- At normal temperatures (20°C/68°F), maximum exposure time is approx. 4 hours when using fresh AAA-size alkaline-manganese batteries. With AA-size alkaline-manganese batteries in the optional Battery Holder BH-70L, exposures up to approx. 9 hours are possible.
- If the camera's mirror locks up during the exposure, set main switch to LOCK, replace the batteries, and slide main switch to ON.
- To use eyepiece cap, refer to page 36.

SELF-TIMER OPERATION

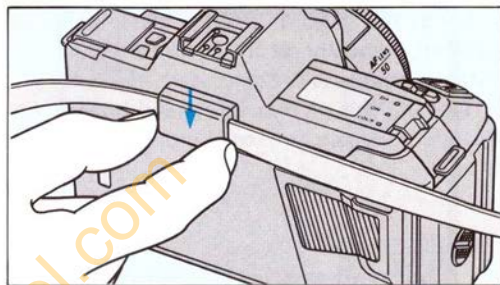
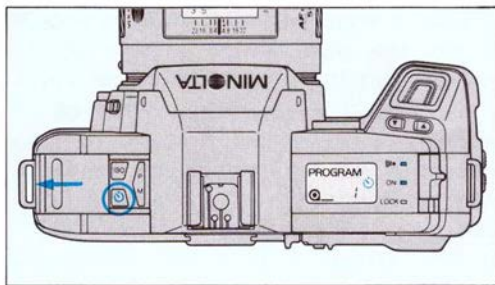

The Minolta 5000's electronic self-timer lets you delay shutter release for ten seconds.

To use:

1. Slide the control-key cover to the left.
2. Press the self-timer key (marked ☺).

The self-timer symbol will appear in the data panel.

- Pressing the key again will switch off the self-timer.
3. Focus the lens and attach the eyepiece cap.

4. Press the operating button all the way down to start the self-timer.

- The number of seconds remaining before the shutter will release are displayed in the data panel.
- If the main switch is at (II) setting, the camera will beep once a second for eight seconds, very rapidly for one second, then emit a continuous tone just before the shutter is released.
- The self-timer is automatically switched off after the exposure. If you want to make another exposure using the self-timer, repeat steps 2-4.

To cancel self-timer operation:

If you have started the self-timer and want to cancel it before the shutter releases, move main switch to LOCK and back to ON position.

app-phot-col.com

DISTANCE SCALE

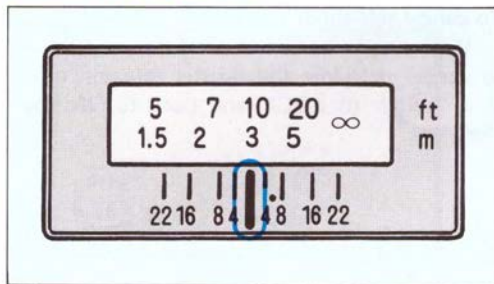

The distance scale marked on each Minolta AF lens is useful when you want to manually focus the lens to a specific distance, or when it is too dark to use autofocus. To use the scale, set the focus mode switch to M estimate the distance to your subject, and turn the focusing ring align the corresponding figure on the distance scale with the index line.

USING A TRIPOD



To prevent blurred pictures, the camera should be mounted on a tripod in the following situations: when making long exposures at “bulb” setting; when using slow shutter speeds; and when using the self-timer.

When you attach the camera to the tripod, do not tighten the tripod’s mounting screw too much. Also, make sure that mounting screw is not longer than 5.4mm (1/4 in.).



USE OF MINOLTA AF LENSES



A wide range of Minolta AF lenses is available for your Minolta 5000. These can be purchased separately from your photo dealer.

The Minolta AF lens system now features focal lengths from 24mm wideangle to 600mm apochromat telephoto. Included are seven macro/zooms covering focal lengths from 28mm to 300mm. Among these outstanding zoom lenses are the ultra-compact 35-70mm and 100-200mm zooms, which enable photographing landscapes or portraits with equal ease.

All Minolta AF lenses attach to the camera in the same way as explained earlier in this manual. When using program mode, the camera instantly selects one of three exposure programs based on the lens focal length in use. This is called as Auto Multi-Program Selection.

Auto Multi-Program Selection

Wide program is set for focal lengths shorter than 35mm: uses smaller apertures to obtain more sharpness (depth of field) when using wideangle lenses.

Standard program is set for focal lengths from 35mm to 105mm: Maintains optimum shutter/aperture combinations for sharp pictures when using the camera hand-held.

Tele program is set for focal lengths longer than 105mm: Faster shutter speeds are used to prevent blurred pictures caused by camera shake or subject movement.

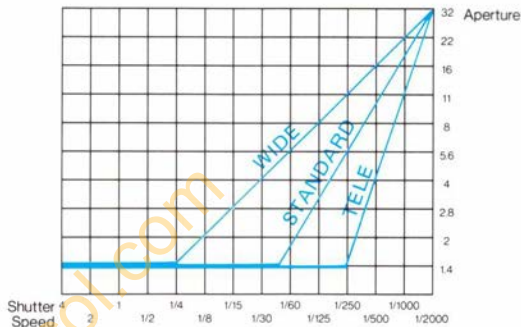

- Since selection of the program is done automatically, it is not possible to manually select a specific program.
- When using an AF zoom lens, the program automatically changes as the focal length is changed from one range to the next. With the AF 28-135mm zoom, for example, as you adjust the focal length from 28mm to 135mm, the program changes from Wide through Standard to Tele.

USE OF MINOLTA PROGRAM FLASH UNITS

When taking pictures in low light or if the slow shutter-speed warning beeps, a Minolta Program Flash unit can be attached to the camera's accessory shoe.

All Minolta Program Flash units feature built-in AF illuminators which extend the working range of the camera's autofocus system. When required in low light, the AF illuminator automatically projects a beam of red light onto the subject, which the camera uses for automatic focusing.

Flash exposure, in both program and manual mode, is controlled automatically by the Minolta 5000's flash metering system. The flash signal in the viewfinder indicates when the flash is charged and if exposure was sufficient.

In program mode: No manual settings are required; the camera sets both the aperture and shutter speed. The X-sync speed is set automatically to 1/60 or 1/100 sec. depending in the light level.

When photographing a subject in direct sunlight, flash can be used to "fill in" the dark shadows. In this case, the camera's flash program automatically adjusts flash output for correct exposure.

In manual mode; Shutter speed can be set to any speed 1/100 sec. or slower. Smaller aperture numbers can be set to obtain maximum flash range for distant subjects or larger numbers can be set for more sharpness in close-up photos.

PROGRAM FLASH UNITS

Program Flash 1800AF: This ultra-compact unit is extremely easy to use; just switch it on and you are ready to shoot. It accepts a 6v lithium battery for shortest recycling, and AAA-size alkaline batteries can also be used. Guide Number is 18 in meters (59 in feet) with 35mm coverage.

Program Flash 2800AF: This intermediate unit provides increased flash power and has a Guide Number of 28 in meters (92 in feet) with 35mm coverage. Other features include high/low power settings and sufficient-exposure confirmation.

Program Flash 4000AF: This powerful unit has a Guide Number of 40 in meters (131 in feet) with 50mm coverage. An auto-zoom/bounce head enables efficient lighting control. The LCD panel shows power level, flash coverage, and flash ranges.

Guide numbers are based on ISO 100



ACCESSORIES



The Data Back 70 enables imprinting of the date, day with 24-hour time, or the hour and minute of exposure. A single 3-volt lithium battery is installed at the factory and supplies power for imprinting and operating the automatic calendar and clock.

The Program Back 70 enables imprinting of the date, day with 24-time, consecutive number in either ascending or descending order, fixed numbers, or a combination of consecutive and fixed numbers. For unmanned camera control, the intervalometer can be set to release the shutter at pre-selected intervals. Timed long-exposures are also possible.

Either unit attaches in place of the Minolta 5000's standard back. Exposure duration for data imprinting is controlled automatically according to the camera's film-speed setting.



Wireless Controller IR-1N Set

The Wireless Controller IR-1N Set permits cordless, remote-control photography from up to 60 meters (approx. 200 ft.) away. The receiver senses infrared pulses from the transmitter and releases the shutter with single or continuous film advance. Separate receivers can be used for remote control of up to three cameras.



Remote Cord RC-1000L and RC-1000S

A remote cord should be used for long exposures at "bulb" setting or anytime you want to release the shutter without shaking the camera. Autofocus and meter are both activated by partially depressing the release button. Pressing and sliding the release button locks the shutter open for long exposures. RC-1000L is 5m (16-1/2 ft.) long, RC-1000S is 50cm (approx. 20 in.) long.

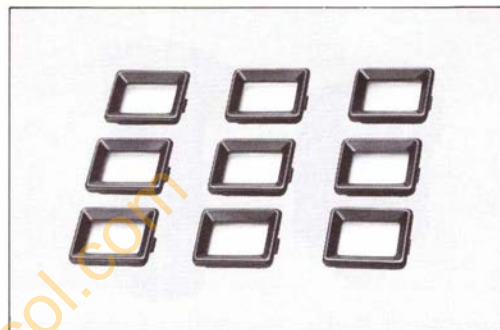

Battery Holder BH-70L and External Battery Pack EP-70

Battery Holder BH-70L replaces the standard AAA-size battery holder. The External Battery Pack EP-70 can be slipped into your pocket to keep them warm when taking pictures in cold weather. The BH-70L and EP-70 both use AA-size alkaline-manganese or nickel-cadmium batteries.

Eyepiece Corrector 1000

Nine eyepiece correction lenses are available for the 5000. They permit adjustments from -4 to $+3$ diopters and are very useful for near-or farsighted photographers. Correction lenses snap into the camera's eyepiece frame.



Minolta Polarizing (Circular) Filter

To reduce or eliminate reflections from glass, water, or other non-metallic surfaces, Minolta's Polarizing (Circular) Filters should be used. If a regular polarizing filter is used, metering may not be accurate. (Light from regular polarizing filters is not fully transmitted by the camera's semi-silvered main mirror.)

Other Filters

Autofocusing can be used with these Minolta filters: L37 (UV), Y52 (yellow), GO (green), O56 (orange), R60 (red), 1B (SKYLIGHT), A12 (85), B12 (80B), ND4X, Minolta Portrayer, and Polaring (Circular).

When using filters other than those listed, autofocusing may not be accurate. In this case, focus manually with filter attached or autofocus and then attach filter.

Other flash units:

All Minolta Auto Electroflash units can be used on the Minolta 5000; however, auto-focusing in total darkness, and certain other features are not possible:

360PX and 132PX: FDC (flash distance check) signal does not function; all other functions are the same.

280PX: FDC signal does not function; low power setting cannot be used.

Macro 80PX: FDC signal does not function; illumination lamps go out when operating button is touched.

X-series units: TTL metering and FDC signal do not function.

Other Minolta system accessories

The following Minolta System accessories can be used with the Minolta 5000:

Angle Finder V_N, Magnifier V_N, Cable OC, Cable EX, Cable CD, Triple Connector, Off-Camera Shoe, Wireless Controller IR-1 Set with optional Connecting Cord IR-1 (C).

app-phot-col.com

IMPORTANT NOTICE

The Minolta AF SLR System is designed and produced to offer innovative functions and performance through the combination of Minolta AF SLR camera bodies, Minolta AF lenses, Minolta Program flash units and other accessories distributed by Minolta.

We thus caution users that the attachment or use of incompatible lenses, flashes and accessories may result in unsatisfactory performance or damage to the Minolta AF SLR cameras or their system accessories.

For optimum performance throughout the life of the Minolta AF SLR cameras and their accessories and to obtain the benefits of future Minolta AF SLR system products, we recommend use only of lenses, flashes and other accessories manufactured by Minolta for the Minolta AF SLR cameras.

app-phot-col.com

TECHNICAL DETAILS

Type: 35mm SLR with autofocus, auto multi-program or manual exposure, and auto film transport

Lens mount: Minolta "A"-type bayonet; accepts all Minolta AF lenses

Autofocus system: Minolta's TTL phase-detection type; working range: EV 2 to 19 at ISO 100; focus signals in viewfinder for both manual and automatic focusing

Shutter: Electronically controlled vertical-traverse focal-plane type

Shutter-speed range: Program mode, stepless 1/2000 to 4 sec. with nearest half-stop displayed in viewfinder; manual (M) mode, 1/2000 to 4 sec. in full stops; "bulb" for long exposures in M mode

Film-speed settings: ISO 25 to 6400 in third-stop increments; automatic setting for DX-coded film; manual setting possible for non-DX film or to override DX-setting

Metering: TTL center-weighted averaging type by silicon photocell (SPC) on pentaprism for ambient light; second SPC at bottom of mirror box for TTL flash metering with dedicated flash unit

Auto-exposure (AE) range: EV -1 to 20 at ISO 100 with 50/1.4 lens (e.g., 4 sec. at f/1.4 to 1/2000 sec. at f/22)

Exposure modes:

Program: Shutter speed and aperture set according to AE program automatically selected by camera: Wide program for focal lengths shorter than 35mm, Standard for focal lengths from 35mm through 105mm, Tele for focal lengths longer than 105mm

Manual: Any available shutter speed (in full-stops) and aperture (in half-stops) can be set; settings and correct exposure indicated in viewfinder

Flash exposure modes: TTL flash metering at film speeds ISO 25-1000

Program: Automatic setting of X-sync to 1/100 sec. (or 1/60 below EV 12) and aperture; automatic fill-in flash in bright sunlight

Manual: Usable shutter speeds 1/100 sec. or slower, any aperture usable; speed automatically reset to 1/100 sec. for manually set speeds 1/125 sec. or faster

Backlight compensation button: In program mode, pressing button marked BLC increases exposure by +2 EV.

Viewfinder: Eye-level fixed pentaprism shows 94% of 24 x 36mm film-frame area; magnification 0.85X with 50mm lens at infinity

Data displays:

Top panel: Displays exposure mode, film speed, frame number, self-timer operation, "bulb" operation, low-battery warning, and film-transport status

Viewfinder: Displays exposure mode, shutter speed, aperture, low-battery warning, whether light level is within metering range, and over-/underexposure warning; display illuminated automatically in low light; LED focus signals, LED flash-ready/sufficient-exposure signal

Film transport: Automatic with built-in motor drive: auto threading, auto advance to first frame, continuous film advance with focus-priority shutter release at up to 1.5 frames per second, power rewinding,

auto rewind stop; frame number increases by one with each exposure only when film is loaded and advancing correctly

Operating button: Touch-sensitive switch activates metering and viewfinder display, metering continues for 10 sec. after finger is lifted from button; press halfway to activate autofocus and focus hold; press all the way down to release shutter

Power: Four AAA-size 1.5v alkaline-manganese batteries power all operations; built-in lithium cell for memory back-up; low power indicated by battery symbol in finder and data panel; sliding main switch with LOCK, ON, and (beep) positions

Audible signals: With main switch at beep position, camera emits audible signals: when subject is in focus; at the end of the roll; during self-timer operation; and as a slow shutter-speed warning in program mode when speed is below: 1/30 sec. with lenses shorter than 35mm, 1/60 sec. with lenses from 35mm to 105mm, and 1/125 sec. with lenses longer than 105mm.

Controls: Keys to select manual mode, set self-timer, and set film speed; selector keys to adjust aperture, shutter speed, and film speed; closing control-key cover sets camera to program mode and cancels self-timer operation.

Self-timer: Electronic with 10-second delay; cancelable; operation indicated by count-down in data panel accompanied by synchronized audible beeps.

Other: Front and rear handgrips, eyepiece cap, film window, remote shutter-release socket, carrying strap

Size and weight: 52 x 92.5 x 138mm (2-1/16 x 3-5/8 x 5-7/16 in.), 550g (19-3/8 oz.) without lens and batteries

Optional accessories: Minolta AF lenses, Program Flash units, Data Back 70, Program Back 70, Eyepiece Correctors, Battery Holder BH-70L, External Battery Pack EP-70, off-camera cables and connectors, Remote Controller IR-1N.

CARE AND STORAGE

- Never touch the shutter curtains or the front inside parts of the body or clean them with compressed air. Doing so may impair their alignment and movement.
- Always keep your camera in its case with the lens capped when not in use, or with a body cap on when a lens is not attached.
- No part of the camera should be forced at any time.
- Never subject your camera to shock, high heat, high humidity, water, or harmful chemicals. Be particularly careful not to leave it in the glove compartment or other places in motor vehicles where it may be subjected to high temperatures.
- Never lubricate any part of the camera body or lens.
- External camera surfaces and lens barrel--but not glass surfaces--can be cleaned by wiping with a dry or silicone-treated cloth.



MINOLTA

app-photocul.com