



*At the heart of the image*

DIGITAL SLR CAMERA

# D70s





## Ready to capture any moment with speed and beauty. The D70s.



• Image quality mode: RAW (NEF) • Lens: AF-S DX Zoom-Nikkor 12-24mm f/4G IF-ED • Exposure mode: [A], 1/1000 second, f/5.6 • White balance: Auto • Sensitivity: ISO-equivalent 200

Inheriting the award-winning image quality, high performance and user-friendliness of the D70, the Nikon D70s introduces refinements that further help photographers freely capture precious moments the instant they unfold.

- 3 fps continuous shooting for up to 144 consecutive shots\*
- 0.2 sec. power-up and short shutter release time lag
- 1/8,000 sec. shutter speed & 1/500 sec. flash sync
- Large 2.0" LCD monitor with intuitive menus and help display (NEW)
- Improved 5-area AF system (NEW)
- 6.1 effective megapixel Nikon DX Format CCD image sensor
- 7 Digital Vari-Program modes
- Built-in Speedlight with flash coverage for 18mm lenses (NEW)
- Optional Remote Cord MC-DC1 (NEW)

\*When using JPEG NORMAL - Large setting, and a SanDisk SDCFH (ultra II), SDCFX (Extreme/Extreme II) or Lexar Media 80X WA CompactFlash™ card

# D70s







## Performance capable of capturing all the action in stride

Speed and precision assure readiness when that special moment arises



### Improved 5-area AF system **NEW**

Nikon's advanced 5-area Multi-CAM900 autofocus system continues to feature a cross-type sensor in the center, broad frame coverage, as well as the same class-leading low light detection and convenient AF-assist illuminator that aid shooting in dark situations. New are



refinements to deliver greater precision with fast, more consistent subject acquisition and improved focus tracking when using Closest Subject Priority Dynamic AF or Dynamic AF mode with predictive focus tracking and Lock-on™.



The AF system automatically determines which focus area should be given priority, prevents the camera from focusing on the background, and improves the focus 'hit rate' when tracking the intended subject.

### 144-picture 3 fps continuous shooting

The D70s can shoot a rapid 3 frames per second for a continuous burst of 144 pictures\* thanks to optimized systems throughout the camera, including high-speed buffer memory handling, fast image processing, high-speed memory card access, and large system bus bandwidth.

\*When using JPEG NORMAL - Large setting, and a SanDisk SDCPH (ultra II), SDCFX (Extreme/Extreme II) or Lexar Media 80X WA CompactFlash™ card

### Near-instant power-up and quick response (0.2 sec. power-up and short shutter release lag)

Turn on the D70s and, with a power-up time of a mere 0.2 seconds, it's ready to shoot immediately. Press the shutter button and it responds without hesitation. Nikon's 5-area Multi-CAM900 autofocus with AF-assist illuminator ensures a fast and precise focus under even challenging lighting conditions. Pictures taken are processed and recorded extremely quickly. Preview images appear on the LCD monitor almost instantly. And, high-speed continuous shooting means never falling behind the pace of the action or missing the heartbeat of the moment.

### Fast shutter speeds (1/8,000 sec. maximum shutter speed & 1/500 sec. flash sync)

Shutter speeds from 30 to 1/8,000 sec. and flash-synchronized shutter speeds of up to 1/500 sec. provide a photo experience with greater breadth and creative flexibility to catch more of those precious moments.





# Performance that produces great pictures with pure color fidelity

Vivid color and sharp details with high resolution and wide dynamic range



• Image quality mode: RAW (NEF) • Lens: AF-S VR Zoom-Nikkor 70-200mm f/2.8G IF-ED • Exposure mode: [A], 1/80 second, f/2.8 • White balance: Cloudy • Sensitivity: ISO-equivalent 200

## Advanced image processing engine



The D70s's advanced System LSI processor produces images with pure, vivid colors and maximum clarity. Auto white balance, auto tone and color control are optimized, while real-time processes diminish digital noise in long exposure shots. Processed images are ready to print right from the camera, minimizing time spent to achieve pleasing results. The image processing engine also maximizes system performance to ensure fast file compression, high-speed data handling in memory, fast simultaneous recording of JPEG and NEF files, and near-instant display of images.

## Nikon DX Format CCD image sensor

Optimized to deliver a wide dynamic range that produces great pictures with high resolution and sharp details, the DX Format CCD sensor's 6.1 effective megapixels yield 3,008 x 2,000-pixel images that are suitable for making large prints, or for creative cropping to bring out detail. Micro-optics incorporated into each of the sensor's pixels precisely align the image from the camera's lens for maximum performance, whether using AF Nikkor lenses or high-quality, digital-dedicated DX Nikkor lenses. All Nikon digital SLR cameras employ the DX Format, establishing a level of high performance and uniformity.



## Three color modes

Nikon's advanced color reproduction system optimizes the three available color modes to best match your subject or intended use.

**Mode I:** Renders natural looking skin tones out of the camera. (sRGB)

**Mode II:** Realizes a wider color range suited for processing or retouching. (Adobe RGB)

**Mode III:** Renders vivid landscape and flora colors out of the camera. (sRGB)

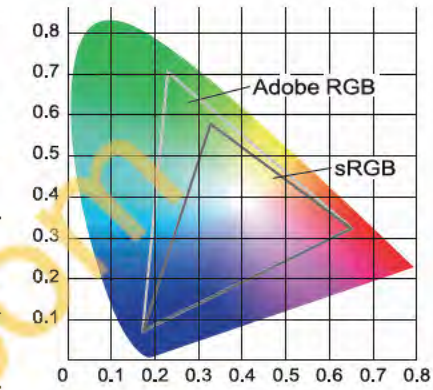

## Nikkor lenses

The D70s employs the Nikon F lens mount for seamless compatibility with the comprehensive lineup of high-quality AF and AF-S Nikkor lenses long favored by professionals around the world for their superb color, high contrast and razor-sharp images, as well as for outstanding autofocus performance. The increasing family of DX Nikkor lenses designed for use with Nikon digital SLR cameras make the options even richer, delivering a wider variety of picture angles, higher performance, and out-standing center-to-edge-to-corner image quality.



18mm



70mm



300mm

When used with the D70s or any Nikon Digital SLR, all AF, AF-S and DX Nikkor lenses have a picture angle comparable to 1.5x that of 35mm [135] format.



### • AF-S DX Zoom-Nikkor 18-70mm f/3.5-4.5G IF-ED

Designed to combine top performance with outstanding value, this compact standard zoom lens covers the highly practical focal length range of 18-70mm, which is equivalent to 27-105mm in 35mm [135] format.



### • AF Zoom-Nikkor 70-300mm f/4-5.6G

With a range ready to cover everything from portraits to sports shooting, this high-power telephoto zoom lens packs a 4.3x zoom ratio into a compact and lightweight package that is ideally suited for traveling. (Equivalent to 105-400mm in 35mm [135] format.)



### • AF Micro-Nikkor 60mm f/2.8D

Nikon's most compact micro lens excels at both close-up and general photography. The medium telephoto reach when used with the D70s (equivalent to 90mm in 35mm [135] format) provides extra working distance for elusive subjects or when supplemental illumination is required.



• Image quality mode: RAW (NEF) • Lens: AF Micro-Nikkor 60mm f/2.8D • Exposure mode: Digital Vari-Program (Close up), 1/30 second, f/3.8 • White balance: Auto • Sensitivity: ISO-equivalent 200





# Performance that delivers accurate control over light

Effective control over exposure, metering, and flash operation



## Automated Digital Vari-Program and exposure modes



Selecting one of the seven Digital Vari-Program selections automatically optimizes white balance, sharpening, tone (contrast), color, saturation and hue settings to best match the selected scene, making creative photography as simple as rotating the mode dial. Choose from **Auto**, **Portrait**, **Landscape**, **Close Up**, **Sports**, **Night Landscape**, or **Night Portrait** for automated performance that makes the D70s the right choice, whether you are still learning how to make great pictures or an experienced photographer simply in a hurry to capture precious moments.

Exposure mode settings provide greater personal control over camera operation. [P] Auto Multi Program mode automatically sets the shutter speed and aperture, and includes Flexible Program for quick selection of alternate exposure-combination settings. [S] Shutter-Priority Auto offers a choice of shutter speeds from 1/8,000 to 30 seconds. [A] Aperture-Priority Auto allows free selection from the complete range of aperture settings. And, [M] Manual gives full control over shutter speed and aperture.

## Image enhancement options

When using Auto Multi Program [P], Shutter-Priority Auto [S], Aperture-Priority Auto [A], or Manual [M] exposure modes, easy-to-set image enhancement options optimize sharpening, tone (contrast), color, saturation and hue to best match the scene or intended use for the picture. Choices include Normal, Vivid, Sharp, Soft, Direct print, Landscape or Custom optimization.

## Precise white balance control

The D70s produces natural coloration by matching white balance to the light source of the shot. Advanced Auto white balance handles most situations, but the flexible options include a choice of six specific manual settings with fine-tuning, (Incandescent, Fluorescent, Direct Sunlight, Flash, Cloudy, and Shade), as well as a preset option for using a gray or white object as a reference for white balance.

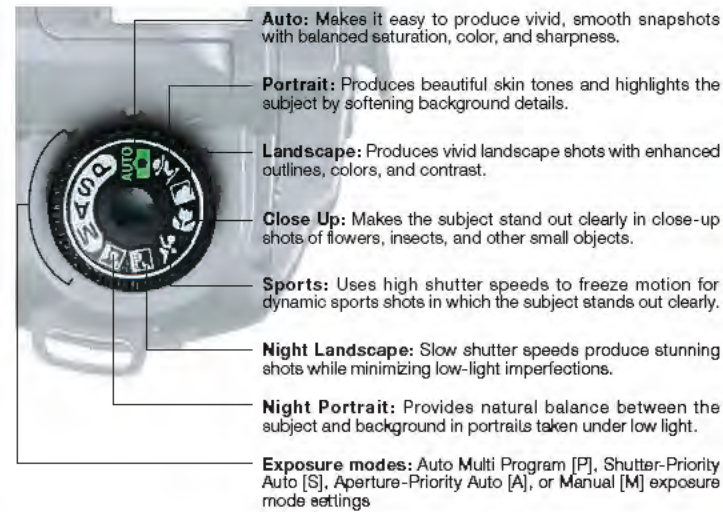

## Exposure metering options

Nikon's 1,005-pixel RGB Exposure/Color Matrix Metering Sensor evaluates brightness, color, contrast, selected focus area, and subject-to-camera distance information, references the results against an onboard database of 30,000 scenes from actual photography and then uses high-speed processing to deliver consistently dependable automatic exposure. Variable center-weighted metering and a choice of five spot meters are also available, as is exposure compensation and auto exposure bracketing.

## Built-in Speedlight with i-TTL flash control (with wider angle coverage) NEW

The built-in Speedlight automatically pops up and fires when natural lighting is inadequate, or to add Balanced Fill-Flash when there is strong backlighting. With a new optimized design for the D70s, flash coverage has been increased to support lenses as wide as 18mm.

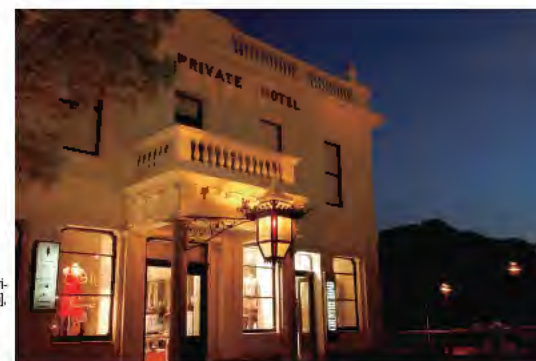

• Image quality mode: RAW (NEF)  
 • Lens: AF-S Zoom-Nikkor 17-35mm f/2.8D IF-ED  
 • Exposure mode: Digital Vari-Program (Night Landscape), 1/60 second, f/5.6  
 • White balance: Auto  
 • Sensitivity: ISO-equivalent 200



• Image quality mode: RAW (NEF) • Lens: AF-S DX Zoom-Nikkor 18-70mm f/3.5-4.5G IF-ED • Exposure mode: [A], 8 second, f/11 • White balance: Auto • Sensitivity: ISO-equivalent 200

## Creative Lighting System support

A major benefit of the D70s's built-in flash is that it adopts Nikon's highly robust and advanced i-TTL flash control, technology that leads the industry in vastly expanding the possibilities for using creative lighting in photography. The built-in Speedlight also works with the Creative Lighting System, serving as a remote commander that controls one group of multiple wireless SB-600 or SB-800 Speedlights. Alternately, attach an SB-800 and control up to 3 wireless remote groups, each consisting of any number of SB-800 or SB-600 Speedlight units.

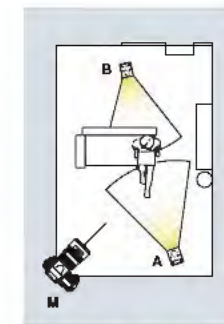

• Image quality mode: RAW (NEF)  
 • Lens: AF-S DX Zoom-Nikkor 18-70mm f/3.5-4.5G IF-ED  
 • Exposure mode: [M], 1/250 second, f/4.5  
 • White balance: Auto  
 • Sensitivity: ISO-equivalent 200  
 • SB-800 mode settings

Master: Flash canceled, Remote A: Manual, Remote B: Manual  
 Wireless multiple flash photography with Nikon's Creative Lighting System helps create more natural-looking pictures by using several flash units to emphasize the subject or eliminate shadows.



On-camera single flash



# Performance that makes it easier to take great pictures

Improved ergonomics for efficient handling and easy operation



## Multi selector and Nikon ergonomics provide greater operating ease

The handy four-direction multi selector on the camera's back makes it easy to select a specific focus area when using Single AF or Dynamic AF modes or to navigate menus and control image playback. The light, compact camera body fits the hand well and ensures easy access to controls which themselves are designed and logically placed for ease of use. This includes the Mode dial and Help button, as well as the Main and Sub Command Dials that facilitate easy control over settings and smooth single-handed operation. The large LCD data control panel atop the camera body allows quick confirmation of important settings. One example of attention to detail is the change in sound frequency used for D70s system beeps, making them more clearly audible.



## Remote cord support **NEW**

The new Remote Cord (MC-DC1) adds greater convenience and ease of use in a wider variety of shooting situations, including long exposures and close-ups. The optional Wireless Remote Control ML-L3 can also be used with the D70s.



• Image quality mode: RAW(NEF)  
• Lens: AF-S Zoom-Nikkor 28-70mm f/2.8D IF-ED  
• Exposure mode: Shutter Priority, 10 seconds, f/8  
• White balance: Incandescent  
• Sensitivity: ISO-equivalent 200  
Photo taken using the Remote Cord MC-DC1.

## Remote camera control support

Using the supplied USB cable to connect the D70s to a computer running Nikon Capture 4 software enables remote control from the computer over most shooting settings as well as triggering of the shutter release. Images can be downloaded directly to the computer, eliminating the need to change memory cards while shooting.



## Large 2.0" LCD monitor and new menu design **NEW**

A new menu design combining a carefully selected color scheme, the right amount of contrast, and larger fonts makes the user-friendly keywords of the menu displays easier to view and quicker to recognize. Playback options on the new 2.0-inch LCD monitor include single frame, 4 or 9-image thumbnail display, zoom with scroll (up to 4.7x), automatic slide show, histogram indication, and highlight point display.



## New higher energy lithium-ion battery **NEW**



The new EN-EL3a rechargeable lithium-ion battery increases energy capacity to deliver enough power to shoot as many as 2,500 images per charge\*, all while maintaining the same form factor as the EN-EL3 battery. The new Quick Charger MH-18a is smaller than the charger it replaces, and is capable of charging both the EN-EL3a and EN-EL3 batteries. When the need arises, the D70s can also be run using CR2 batteries. (Requires the optional CR2 battery holder, MS-D70).

\*Achieved under following test conditions: Fully charged EN-EL3a battery; temperature of 20°C/68°F; Zoom-Nikkor AF-S DX 18-70mm f/3.5-4.5G IF-ED lens; continuous shooting mode; continuous-servo autofocus; image quality set to JPEG BASIC; image size set to Medium; shutter speed 1/250 sec.; shutter release pressed halfway for three seconds and focus cycled from infinity to minimum range three times with each shot; monitor turned on for five seconds after six shots and then turned off; cycle repeated once exposure meters have turned off.

## Viewfinder

The bright optical viewfinder features Vari-Brite Focus Area display, which makes focus confirmation easier by automatically superimposing the selected focus area in black when lighting is sufficient, but momentarily illuminating it in red when shooting in dim light or focusing on a dark-colored subject. On-Demand grid lines superimpose a grid over the viewfinder that can prove helpful for architectural photography or shooting landscapes that include horizons. A digital readout along the bottom displays valuable information on settings and camera status.





# Versatility that makes digital photography more rewarding

Flexible settings and powerful software enhance shooting and the results

## Variety of custom settings

A total of 25 custom settings help personalize the operation of the D70s to match individual shooting styles, or optimize it for use under the demands of different shooting conditions. The custom settings menu is displayed on the LCD monitor in easy-to-understand fashion, and selections are made using the handy multi selector on the camera's back. Help dialogs that describe each setting can also be displayed with the press of a button.

## Simultaneous NEF + JPEG recording

The D70s's ability to simultaneously save individual NEF (RAW) and JPEG files for the same image helps optimize workflow operations for varying conditions and needs.

## Storage media (CF Card, Microdrive™)

The D70s is compatible with CompactFlash™ cards and Microdrive™ media of up to 4GB capacity.



The following CompactFlash™ cards can be used with the D70s:

- SanDisk Corporation
  - SDCFB 32/128/256/512MB/1GB, SDCFB (Type II) 192/300MB, SDCF2B (Type II) 256MB, SDCFH (Ultra) 128/256/384/512MB/1GB, SDCFH (Ultra II) 256/512MB/1GB, SDCFV (Extreme) 512GB, SDCFV (Extreme III) 1GB/2GB
- Lexar Media Corporation
  - 12X USB series: 64/128/256/512, 16X USB series: 256/512/1GB, 16X WA USB series: 128/256/512MB, 24X USB series: 256/512MB, 24X WA USB series: 256/512MB, 32X WA USB series: 1GB, 40X WA USB series: 256/512MB/1GB/4GB, 80X WA series: 512/1GB/2GB/4GB
- Renesas Technology (Hitachi)
  - HB28BxxxC8x series: 16/32MB
- Microdrive™
  - DSCM-11000 (1GB), 3K4-2 (2GB), 3K4-4 (4GB)

Operation is not guaranteed with cards produced by other manufacturers. For more details on the above cards, please contact the relevant manufacturer.

## PictBridge support

Printing pictures can be as simple as connecting the D70s to any PictBridge compatible printer via the supplied USB cable. The D70s improves PictBridge support by adding in-camera page setup support for easier printing and greater control over the results.



## Nikon Capture 4 (Ver. 4.2)

Nikon Capture 4 offers a unique image-editing environment and is the only program that provides complete functionality to edit NEF (Nikon Electronic Format) files, enabling photographers to optimize output for every possible need.

### The NEF difference

Nikon Electronic Format (NEF) is a unique file format consisting of an image's RAW data, along with an instruction set that provides unparalleled image editing capability. With NEF, all corrections and adjustments made are saved in the file's instruction set. The original file's RAW data is never altered, regardless how many times the instruction set is changed. Instruction sets can also be saved separately for all adjustments or only selected parameters, and then later applied to individual files or to a large number using automated batch processing. It's the best of versatile image editing combined with precious savings in hard disk space.

Nikon Capture 4 processes and displays NEF files using a full 16 bits per color channel for smoother fidelity when making tonal and other color corrections. Changes can be saved to the NEF file, as a new Instruction Set, or as a TIFF or JPEG file.

Version 4.2 continues to refine the power, speed and flexibility of Nikon Capture 4. Building on familiar features such as Fisheye-to-rectilinear image transformation, Image Dust Off and batch processing, a number of new functions expand the creative possibilities and improve workflow efficiency.

### •D-Lighting:

adjusts shadows and highlights while maintaining mid-tones for optimized results that compensate for underexposure and overexposure.



### •Straighten:

rotates a picture to level it on the horizontal or vertical axis using either a simple defining mouse action, or by directly entering the amount of rotation to be applied. (±10°)



•Improved color noise reduction — better filters out color noise for smoother transitions while preventing resolution loss at higher settings.

### •Histogram tool:

displays a histogram that more closely represents the final image, and that can be used to confirm specific ranges of pixels in the image window.

### •Marker:

saves the parameters for each image at each step during processing, making it easy to apply distinct finishing touches when preparing the same image for different applications.

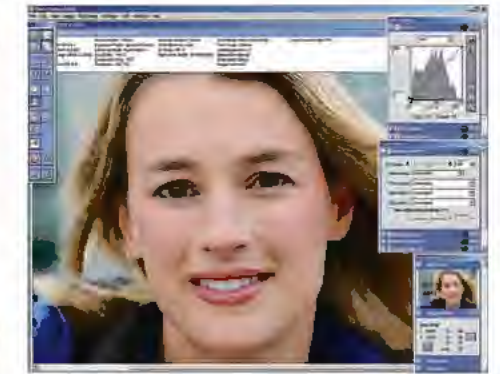

### •Improved Multi Image window:

opens more quickly, and the new scrollable thumbnail image display is also faster. The interface adds new features, including simultaneous editing of multiple files, the ability to undo or redo commands, and file deletion.

### •Photo Effects tool:

applies monochrome, sepia or tint effects, and provides both manual and auto brightness control.

### •Plug-in filter support:

allows feature set expansion for even greater capability to enhance and transform images. The three editions of nik Color Efex Pro 2.0 for Nikon Capture 4 as well as nik Color Efex Pro 2.0 Express Edition offer selections of a wide range of filters and effects packaged to match differing needs.

### Remote Camera Control

Nikon Capture Control can control most shooting settings and trigger the D70s's shutter release remotely from a computer when the camera is connected via the USB interface to a computer with Nikon Capture 4 installed.



## PictureProject

PictureProject is refined with an intuitive new user interface that makes image management, editing and sharing easier and more fun. Simply connect the camera to a computer to automatically import pictures. Quickly e-mail or Auto Enhance images, run slideshows, burn CD/DVDs\*, and access other commonly used functions via practical buttons. Use drag-and-drop to organize pictures into separate collections, and

quickly locate any file by name, keyword, or date. Plug-in filter support offers feature set expansion, including compatibility with the wide range of filters and effects offered by nik Color Efex Pro 2.0. And, with support for JPEG, TIFF and NEF files, PictureProject seamlessly bridges workflow with the powerful feature set of Nikon Capture 4.

\* DVD burning requires the optional PictureProject DVD Show.



## PictureProject System Requirements

	Windows	Macintosh
OS	Preinstalled versions of Windows XP Home Edition, Windows XP Professional, Windows 2000 Professional, Windows Millennium Edition (Me), Windows 98 Second Edition (SE)	Mac OS X version 10.1.5 or later (Mac OS X version 10.2.8 or later required for "Burn Disc" function)
CPU/Model	300 MHz Pentium or better recommended (500 MHz Pentium III or better for muvee option)	Model with built-in USB or FireWire port
HDD	60MB required for installation	
RAM	64MB or more (128MB or more with RAW images or muvee option)	
Display	800 x 600 pixels or more with 16-bit color (High Color / thousands of colors) or more	
Others	<ul style="list-style-type: none"> <li>CD-ROM drive required for installation. Write-capable drive required for "Burn Disc" function.</li> <li>Internet connection required for some options. E-mail option requires Internet connection and supported e-mail program.</li> </ul>	

Note 1: Data transfer may not work properly if the connection to a computer is via a USB hub.

## Nikon Capture 4 (Ver. 4.2) System Requirements

	Windows	Macintosh
OS	Preinstalled versions of Windows XP Home Edition, Windows XP Professional, Windows 2000 Professional, Windows Millennium Edition (Me), Windows 98 Second Edition (SE)	Mac OS 9.0.4, 9.1, 9.2, Mac OS X (version 10.1.5 or later)
CPU/Model	300 MHz Pentium or better recommended	iMac, iMac DV, Power Macintosh G3 (Blue/White), Power Mac G4 or later, iBook, PowerBook G3 or later
RAM	256MB (768MB or more recommended)	Mac OS X: 256MB (768MB or more recommended) Mac OS 9: memory allocation of 64MB or more to Nikon Capture 4 Camera Control, 512MB or more to Nikon Capture 4 (Ver. 4.2)
HDD	200MB required for installation	
Display	800 x 600 pixels or more with 16-bit color (High Color/thousands of colors). 24-bit color (True Color/millions of colors) recommended	
Others	<ul style="list-style-type: none"> <li>CD-ROM drive required for installation.</li> <li>Only computers with built-in USB ports supported.</li> </ul>	

Note 1: Data transfer may not work properly if the connection to a computer is via a USB hub. Note 2: Installation and usage require user authorization.



# A wealth of accessories for optimizing performance and adaptability

## • Remote Cord MC-DC1

The new Remote Cord MC-DC1 was developed as a convenient option for landscape and macro photography, one that makes the camera more convenient and even easier to use. (Approx. 1.0m in length.)



## • Speedlight System

Powerful, full-featured with i-TTL flash control for use with Nikon's Creative Lighting System.



## Accessories

### • COOLWALKER MSV-01

Nikon's original compact digital photo storage device features view-anywhere convenience and versatile compatibility.

### • Wireless Remote Control ML-L3

Cable-free remote triggering of the shutter makes it easier to use slow shutter speeds without disturbing the camera.

### • Hot Shoe Sync Terminal Adapter AS-15

Provides an additional PC sync connector for easy connection of external studio Speedlights.

### • Semi-Soft Case CF-D70



## Power Accessories

### • Rechargeable Li-ion Battery EN-EL3a (supplied)

### • Quick Charger MH-18a (supplied)

### • Multi Charger MH-19

### • AC Adapter EH-5

### • CR2 Battery Holder MS-D70

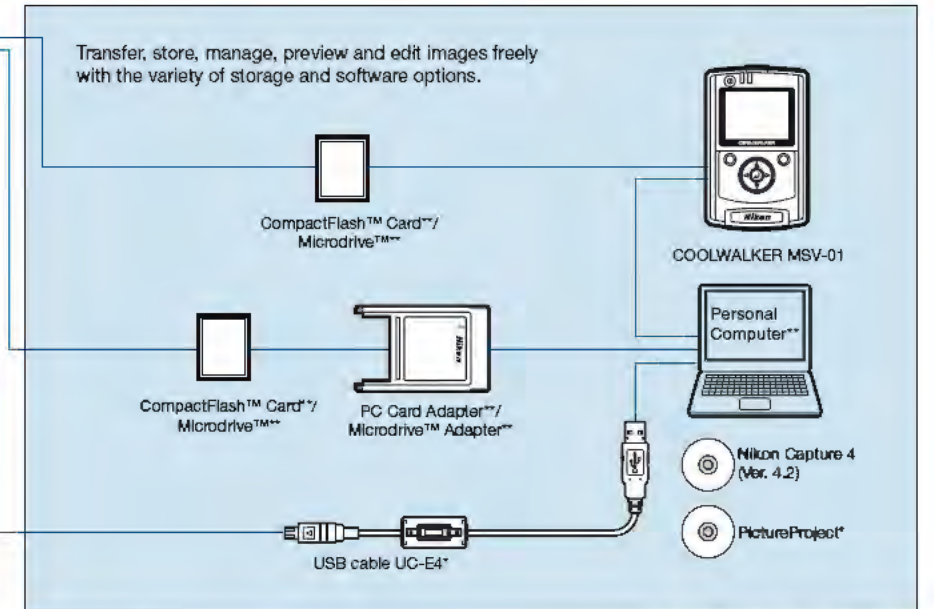
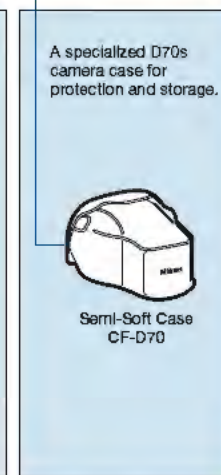
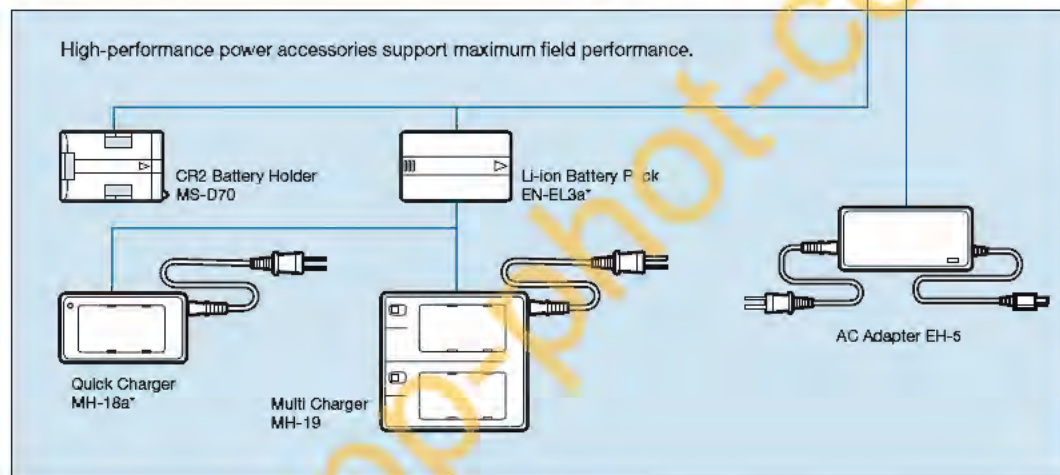
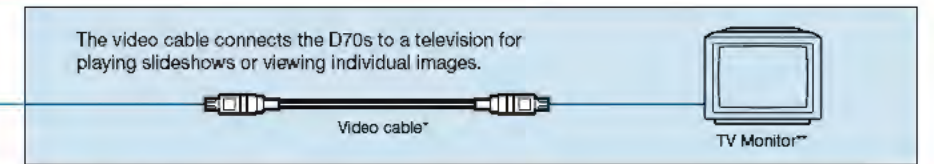
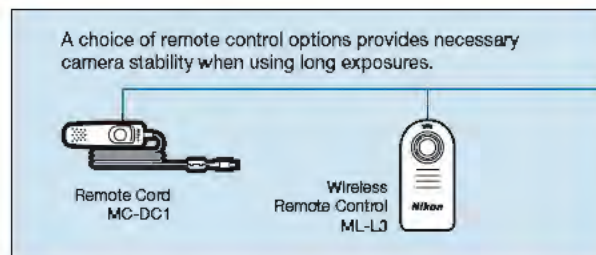
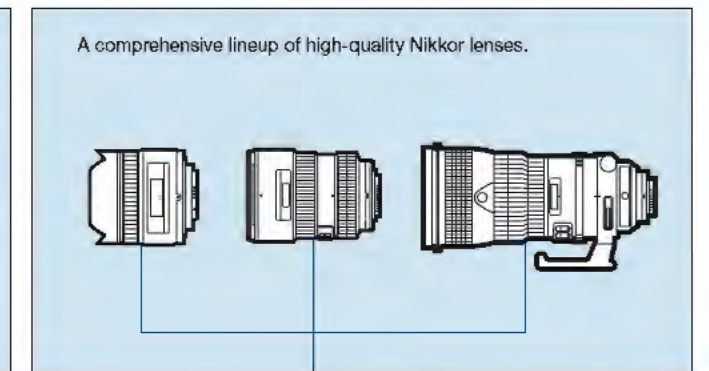
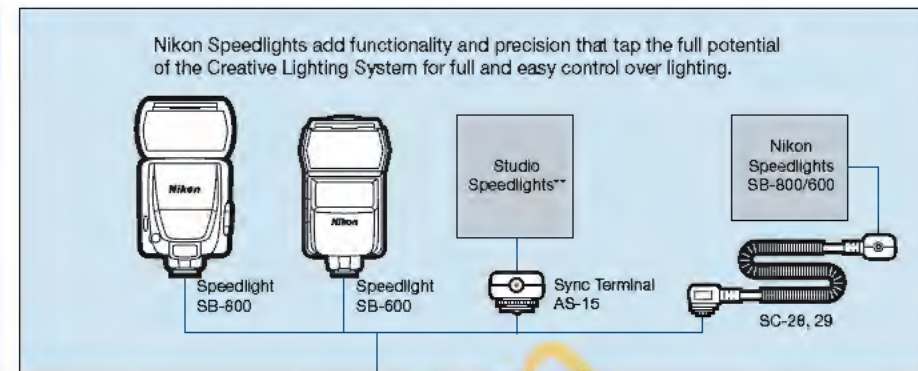
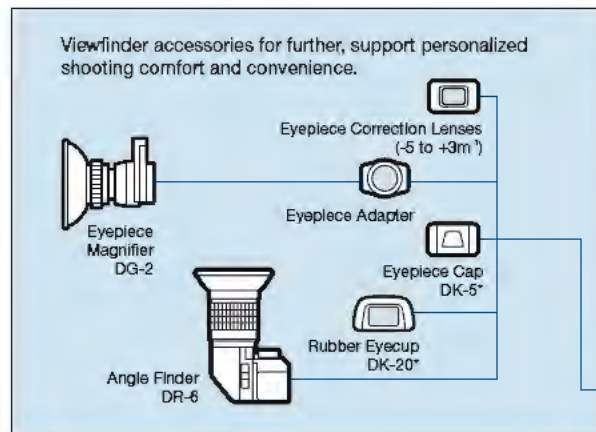

## Function Compatibility Chart (IX-Nikkor lenses cannot be used)

Lens / accessory	Camera setting				Focus Mode			Exposure Mode			Metering System		
	AF	M (with electronic rangefinder)	M	DVP P, S, A	M	3D	Color	3	3	3	3	3	
CPU lenses <sup>1</sup>	Type G or D AF Nikkor AF-S, AF-I Nikkor	✓	✓	✓	✓	✓	✓	✓	✓	✓	✓	✓	
	PC-Micro Nikkor 85mm f/2.8D <sup>4</sup>	-	✓ <sup>5</sup>	✓	-	✓	✓	-	✓	✓	✓	✓	
	AF-S / AF-I Teleconverter <sup>6</sup>	✓ <sup>7</sup>	✓ <sup>7</sup>	✓	✓	✓	✓	✓	✓	✓	✓	✓	
	Other AF Nikkor (except lenses for F3AF)	✓ <sup>8</sup>	✓ <sup>8</sup>	✓	✓	✓	✓	✓	✓	✓	✓	✓	
Non-CPU lenses <sup>10</sup>	AI-P Nikkor	-	✓ <sup>9</sup>	✓	✓	✓	✓	-	✓	✓	✓	✓	
	AI, AI-S, or Series E, AI modified Nikkor AI modified	-	✓ <sup>9</sup>	✓	-	✓ <sup>11</sup>	-	-	-	-	-	-	
	Medical Nikkor 120mm f/4	-	✓	✓	-	✓ <sup>12</sup>	-	-	-	-	-	-	
	Reflex-Nikkors	-	-	✓	-	✓ <sup>11</sup>	-	-	-	-	-	-	
	PC-Nikkor	-	✓ <sup>5</sup>	✓	-	✓ <sup>11</sup>	-	-	-	-	-	-	
AI-type Teleconverter	-	✓ <sup>7</sup>	✓	-	✓ <sup>11</sup>	-	-	-	-	-	-		
PB-6 Bellows Focusing Attachment <sup>13</sup>	-	✓ <sup>7</sup>	✓	-	✓ <sup>11</sup>	-	-	-	-	-	-		
Auto extension rings (PK-series 11-A, 12, or 13; PN-11)	-	✓ <sup>7</sup>	✓	-	✓ <sup>11</sup>	-	-	-	-	-	-		

1 IX Nikkor lenses cannot be used.  
 2 Vibration Reduction (VR) supported with VR lenses.  
 3 Spot metering meters selected focus area.  
 4 The camera's exposure metering and flash control systems do not work properly when shifting and/or tilting the lens, or when an aperture other than the maximum aperture is used.  
 5 Electronic rangefinder cannot be used during shifting or tilting.  
 6 Compatible with AF-I Nikkor lenses and with all AF-S lenses except DX 12-24mm f/4G, ED 17-35mm f/2.8D, DX 17-55mm f/2.8G, DX ED 16-70mm f/3.5-4.5G, ED 24-85mm f/3.5-4.5G, VR ED 24-120mm f/3.5-5.6G, and ED 28-70mm f/2.8D.  
 7 Compatible with lenses with maximum effective aperture of f/5.6 or faster.  
 8 If AF 80-200mm f/2.8S, AF 35-70mm f/2.8S, new-model AF 28-85mm f/3.5-4.5S, or AF 28-85mm f/3.5-4.5S is zoomed in while focusing at minimum range, image on matte screen in viewfinder may not be in focus when in-focus indicator is displayed. Focus manually using image in viewfinder as guide in such circumstances.  
 9 With maximum aperture of f/5.6 or faster.  
 10 Some lenses cannot be used.  
 11 Can be used in mode M, but camera exposure meter cannot be used.  
 12 Can be used in mode M at shutter speeds slower than 1/125 s, but camera exposure meter cannot be used.  
 13 Attach in vertical orientation (can be used in horizontal orientation once attached).





## Nikon Digital SLR Camera D70s Specifications

Type of Camera	Single-lens reflex digital camera
Effective Pixels	8.1 million
Image Sensor	RGB CCD, 23.7 x 15.6mm; total pixels: 6.24 million
Image Size (pixels)	3,008 x 2,000 [L], 2,240 x 1,488 [M], 1,504 x 1,000 [S]
Sensitivity	200 to 1600 (ISO equivalent) in steps of 1/3 EV
Storage Media	CompactFlash™ (CF) Card (Type I and II) and Microdrive™
Storage System	Compressed NEF (RAW); 12-bit compression, JPEG: JPEG baseline-compliant
File System	Exif 2.21, Compliant DCF 2.0 and DPOF
Storage (Number of frames per 256MB CF card, image size L)	RAW approx. 44, FINE approx. 73, NORMAL approx. 144, BASIC approx. 279, RAW & BASIC approx. 39
White Balance	Auto (TTL white balance with 1,005-pixel RGB sensor), six manual modes with fine-tuning, preset white balance, white balance bracketing possible
LCD Monitor	2.0-in., 130,000-dot, low-temperature polysilicon TFT LCD with brightness adjustment
Playback Function	1 frame: Thumbnail (4 or 9 segments); Magnifying playback; Slide show; Histogram indication; Highlight point display; Auto image rotation
Delete Function	Card format, All frames delete, Selected frames delete
Video Output	Can be selected from NTSC and PAL
Interface	USB: Mass storage and PTP selectable
Text Input	Up to 36 characters of alphanumeric text input available with LCD monitor and multi-selector; stored in Exif header
Compatible Lenses	Refer to page 14
Picture Angle	Equivalent in 35mm [135] format is approx. 1.5 times lens focal length
Viewfinder	Fixed eye-level pentaprism-mirror type; built-in diopter adjustment (-1.6 to +0.5m <sup>-1</sup> )
Eyepoint	18mm (-1.0m <sup>-1</sup> )
Focusing Screen	Type-B BritaView Clear Matte screen Mark V with superimposed focus brackets and on-demand grid lines
Viewfinder Frame Coverage	Approx. 95%
Viewfinder Magnification	Approx. 0.75x with 50mm lens at infinity; -1.0m <sup>-1</sup>
Viewfinder Information	Focus indications, AE/FV lock indicator, Shutter speed, Aperture value, Exposure/Exposure compensation indicator, Exposure mode, Flash output level compensation, Exposure compensation, Number of remaining exposures, Flash-ready indicator
Autofocus	TTL phase detection by Nikon Multi-CAM900 autofocus module with AF-assist illuminator (approx. 0.5m to 3.0m) Detection range: EV -1 to +19 (ISO 100 equivalent, at normal temperature: 20°C)
Lens Servo	1) Autofocus (AF): single-servo AF (AF-S); continuous servo AF (AF-C); predictive focus tracking automatically activated according to subject status 2) Manual focus (M)
Focus Area	Can be selected from 5 focus areas
AF Area Mode	1) Single Area AF, 2) Dynamic Area AF, 3) Closest Subject Priority Dynamic Area AF
Focus Lock	Focus can be locked by pressing shutter-release button halfway (single-servo AF) or by pressing AE-L/AF-L button
Exposure Metering System	TTL full-aperture exposure metering system (1) 3D Color Matrix Metering with 1,005-pixel RGB sensor (2) Center-weighted: Weight of 75% (8mm dia. circle) given to 6, 8, 10, or 12mm dia. circle in center of frame, or weighting based on average of entire frame (3) Spot: Meters 2.3mm dia. circle (about 1% of frame) centered on active focus area
Exposure Metering Range	1) EV 0 to 20 (3D Color Matrix or center-weighted metering) 2) EV 2 to 20 (spot metering) (ISO 100 equivalent, f/1.4 lens, 20°C)
Exposure Mode	Digital Vari-Program (A to, P, Portrait, Landscape, Close up, Sports, Night landscape, Night portrait), Programmed Auto [P] with flexible program; Shutter-Priority Auto [S]; Aperture Priority Auto [A]; Manual [M]
Exposure Compensation	±5 EV in increments of 1/3 or 1/2 EV
Auto Exposure Lock	Luminosity locked at detected value with AE-L/AF-L button
Auto Exposure Bracketing	Two or three frames ±2 EV in 1/3 or 1/2 steps

◆Microsoft® and Windows® are either registered trademarks or trademarks of Microsoft Corporation in the United States and/or other countries. ◆Macintosh® is a registered trademark or a trademark of Apple Computer Inc. in the United States and/or other countries. ◆CompactFlash™ is a trademark of SanDisk Corporation. ◆Products and brand names are trademarks or registered trademarks of their respective companies. ◆Images on LCDs and monitors shown in this brochure are simulated.

Specifications and equipment are subject to change without any notice or obligation on the part of the manufacturer. April 2005 © 2005 NIKON CORPORATION

**WARNING** TO ENSURE CORRECT USAGE, READ MANUALS CAREFULLY BEFORE USING YOUR EQUIPMENT. SOME DOCUMENTATION IS SUPPLIED ON CD-ROM ONLY.



NIKON CORPORATION  
Fuji Bldg., 2-3, Marunouchi 3-chome, Chiyoda-ku,  
Tokyo 100-8331, Japan  
<http://nikonimaging.com/>

Shooting Modes	1) Single frame shooting mode 2) Continuous shooting mode: Approx. 3 frames per second 3) Self-timer mode 4) Delayed remote mode: 2 sec. delay 5) Quick-response remote mode
Shutter	Combined mechanical and CCD electronic shutter 30 to 1/8000 sec. in steps of 1/3 or 1/2 EV, bulb
Sync Contact	X-contact only; flash synchronization up to 1/500 sec
Flash Control	1) TTL: TTL flash control by 1,005-pixel RGB sensor Built-in Speedlight: i-TTL Balanced Fill-Flash or standard i-TTL flash (spot metering or mode dial set to [M]) SB-800 or 600: i-TTL Balanced Fill-Flash or standard i-TTL flash (spot metering) 2) Auto aperture: Available with SB-800 with CPU lens 3) Non-TTL Auto: Available with Speedlights such as SB-800, 80DX, 2800, 28, 27, and 22s 4) Distance-priority manual available with SB-800
Flash Sync Mode	1) Front-curtain Sync (normal sync), 2) Red-eye Reduction, 3) Red-eye Reduction with Slow Sync, 4) Slow Sync, 5) Rear-curtain Sync
Built-in Speedlight	☞, ☞, ☞ auto flash with auto pop-up [P], [S], [A], [M]: manual pop-up with button release Guide number (ISO 200/ISO 100, m) approx. 15/11 (manual full 1/12)
Flash Compensation	-3 to +1 EV in increments of 1/3 or 1/2 EV
Accessory Shoe	Standard ISO hot shoe contact with safety lock, provided
Self-timer	Electronically controlled timer with 2 to 20 seconds duration
Depth of Field Preview	When CPU lens is attached, lens aperture can be stopped down and previewed by pressing the preview button
Remote Control	Via Remote Cord MC-DC1 (optional) or Wireless Remote Control ML-L3 (optional)
Power Source	Rechargeable Li-Ion Battery EN-EL3a or EN-EL3, Three CR2 Lithium batteries (with optional MS-D70 CR2 battery holder), AC Adapter EH-5 (optional)
Tripod Socket	1/4 in. (ISO 1222)
Dimensions (W x H x D)	Approx. 140 x 111 x 78mm
Weight	Approx. 600g without battery, memory card, body cap, or monitor cover
Supplied Accessories*	Rechargeable Li-Ion Battery EN-EL3a, Quick Charger MH-18a, Video Cable, USB Cable UC-E4, Strap, Body cap, Eyepiece Cap DK-5, Rubber Eyecup DK-20, LCD monitor cover BM-5, PictureProject CD-ROM
Optional Accessories	Rechargeable Li-Ion Battery EN-EL3a, Multi Charger MH-13, Quick Charger MH-18a, AC Adapter EH-5, CR2 Battery Holder MS-D70, Speedlight SB-800/600, Angle Finder DR-6, Nikon Capture 4 (ver. 4.2) Software, Semi-Soft Case CF-D70, Remote Control ML-L3, Remote Cord MC-DC1, CompactFlash™ Card

\*Supplied accessories may differ in each country or area.

### Image Quality, Image Size and Number of Available Shots (when using 256MB CF card)

Image Quality	Image Size	File Size	Number of Available Shots*	Number of Consecutive Shots Available**
RAW	—	Approx. 5.0MB	Approx. 44 shots**	4 shots
	L	Approx. 2.9MB	Approx. 79 shots	14 shots
FINE	M	Approx. 1.8MB	Approx. 130 shots	10 shots
	S	Approx. 0.8MB	Approx. 279 shots	279 shots
	L	Approx. 1.5MB	Approx. 144 shots	144 shots
NORMAL	M	Approx. 0.8MB	Approx. 253 shots	10 shots
	S	Approx. 0.4MB	Approx. 526 shots	526 shots
	L	Approx. 0.6MB	Approx. 279 shots	279 shots
BASIC	M	Approx. 0.4MB	Approx. 481 shots	9 shots
	S	Approx. 0.2MB	Approx. 950 shots	950 shots
	L	Approx. 0.5MB	Approx. 39 shots**	4 shots

\*1. May change according to shooting conditions. \*2. Number of frames when using the SanDisk SDCFH (ultra II) 256MB CF card. \*3. The number of continuous shots possible in a single burst may be lower depending on the type of CF card used. \*4. The displays show "23" as the number of remaining exposures. \*5. The displays show "21" as the number of remaining exposures.



<http://nikonimaging.com/global/activity/npcci>

